

Impact of Wind Generation on Power System Stability

Markus Pöller/DIGSILENT



Power System Stability

- „Stability“ - general definition:

Ability of a system to return to a steady state after a disturbance.

- Small signal effects
- Large signal effects (nonlinear dynamics)

- **Power System Stability - definition according to CIGRE/IEEE:**
 - Rotor angle stability (oscillatory, transient-stability)
 - Voltage stability (short-term, long-term, dynamic)
 - Frequency stability

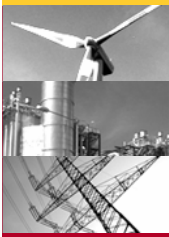

Local effects:

- Loss of synchronism of an individual generator.
- „Run-away“ condition of induction generators.
- Trip of wind generators due to voltage sags.
- Voltage stability at the wind farm connection point

Global effects:

- Loss of synchronism between network areas -> islanding
- Inter-area oscillations with insufficient damping
- Frequency drop -> excessive load shedding
- Voltage collapse -> system blackout

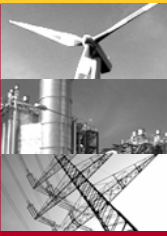

WTG with Induction Generator: Response to Grid Fault

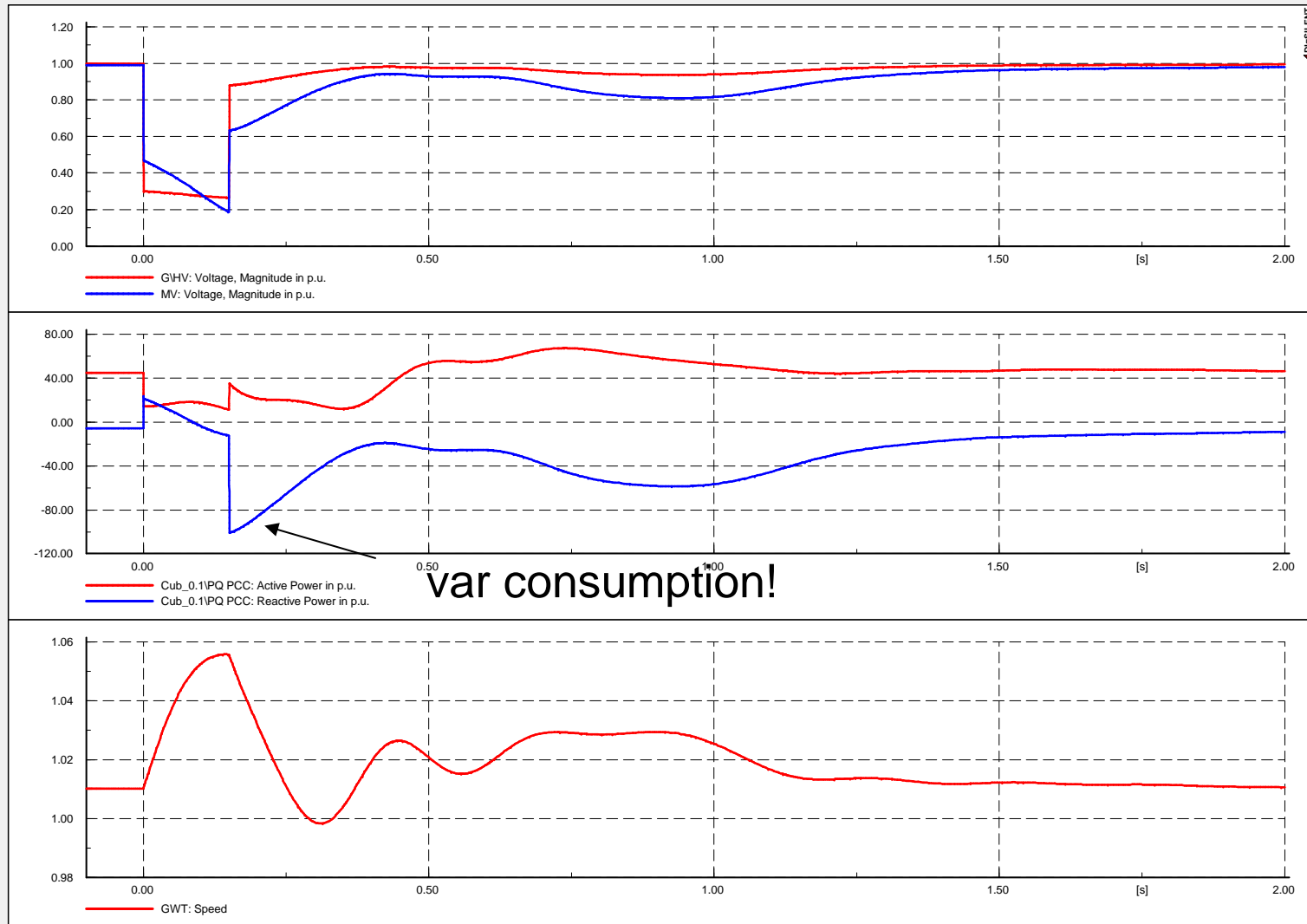



Induction Generators – „Transient Stability“

- Induction generators don't show any rotor angle stability problem, but dynamic voltage stability problems
- Dynamic voltage collapse is a risk because reactive power consumption during voltage recovery can be huge.
- Fixed speed induction generators can “run away” in case of grid faults.
- Induction generators with variable rotor resistance: In principle, same problems exist but fast variation of rotor resistance can mitigate dynamic voltage stability problems
- Additional dynamic reactive power compensation (STATCOM) can help WTGs with induction generators to ride through faults.

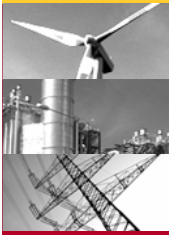

DFIG Response to Grid Fault

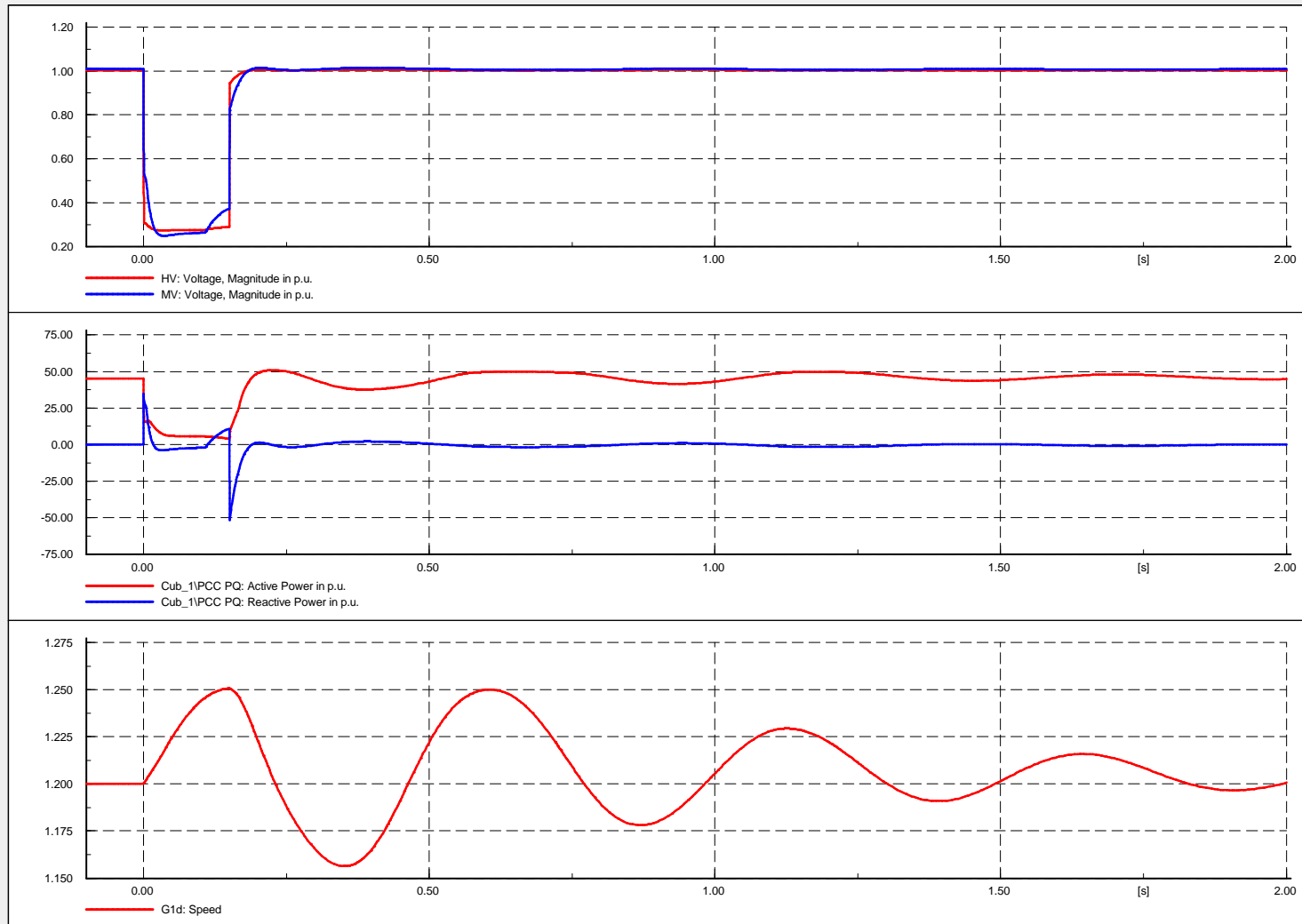

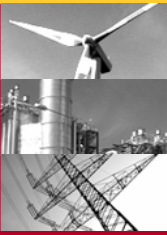

WTG with Fully Rated Converter: Response to Grid Fault

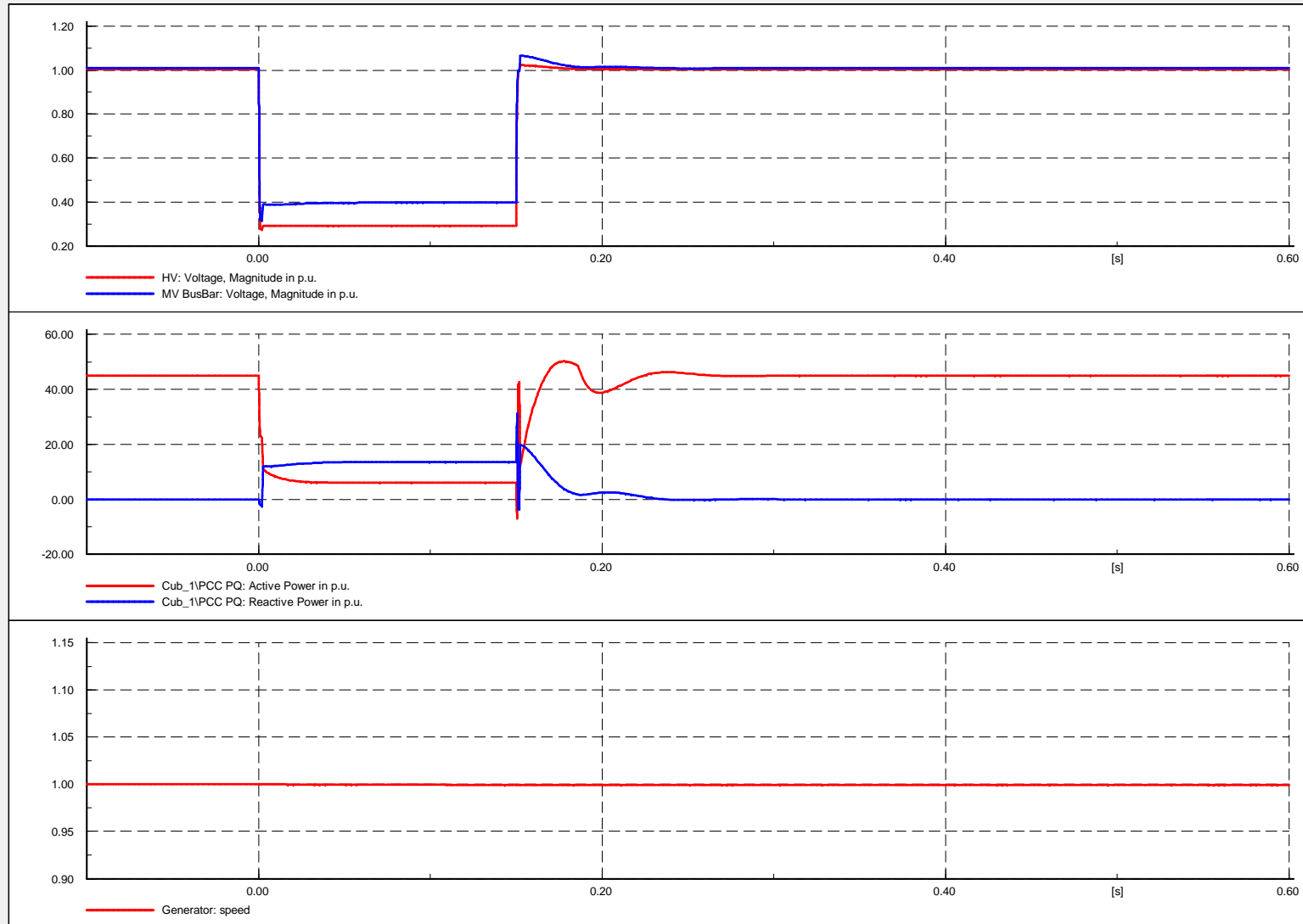



Loss of Synchronism – „Transient Stability“

- Modern variable Speed wind generators (DFIG, fully rated converter) don't show any rotor angle stability problem.
- Variable speed wind generators -> mechanical and electrical angles fully decoupled
- Classical „transient stability“ issue doesn't exist in case of variable speed WTGs.
- Wind generator with FRT-capability required for ensuring local stability in case of grid faults.



Voltage Stability at Grid Connection Point

- Example: Large wind farms connected by long AC-lines

Critical Contingency:
Trip of 1 circuit

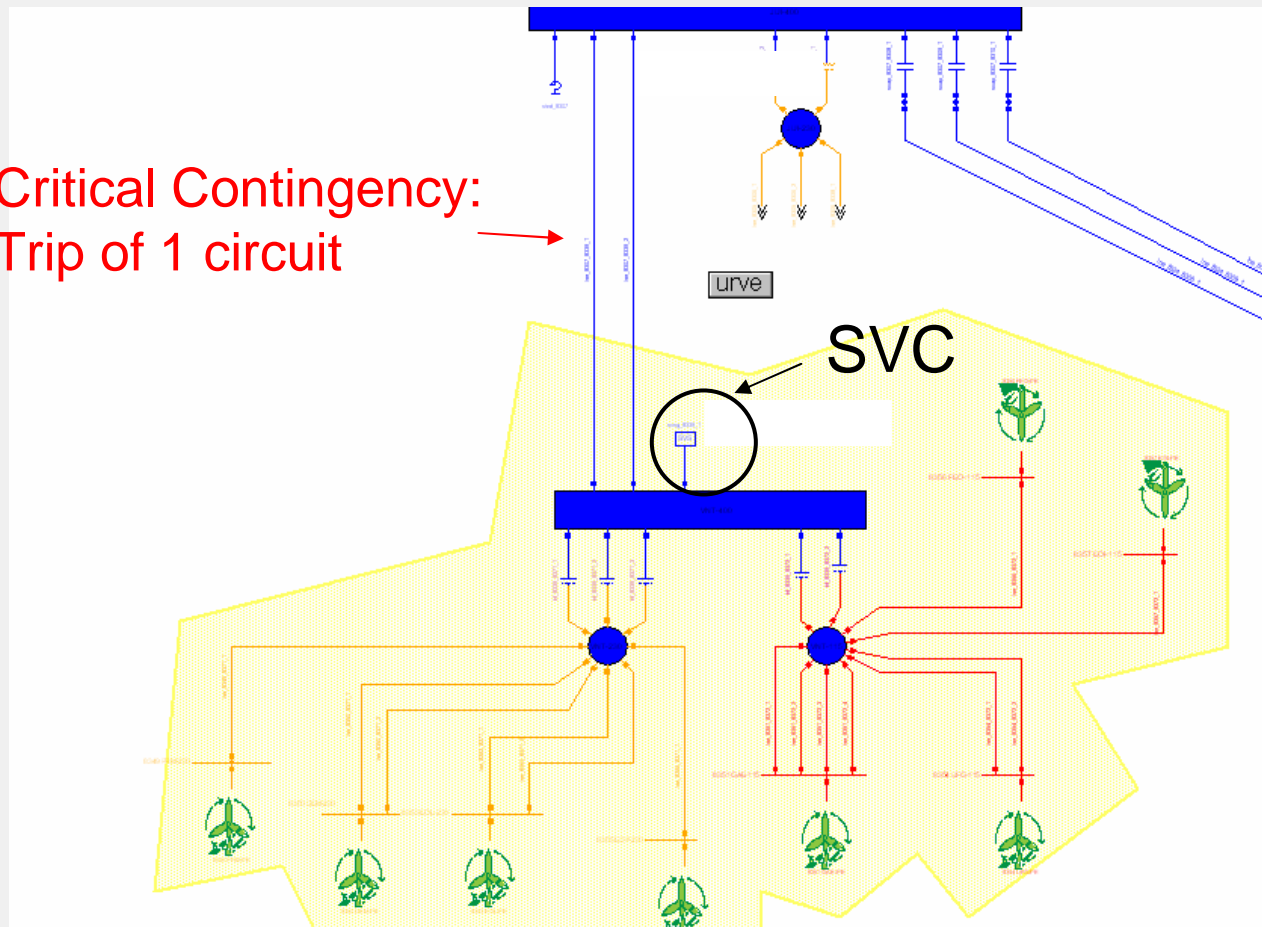



Required Reactive Range (P=0MW)

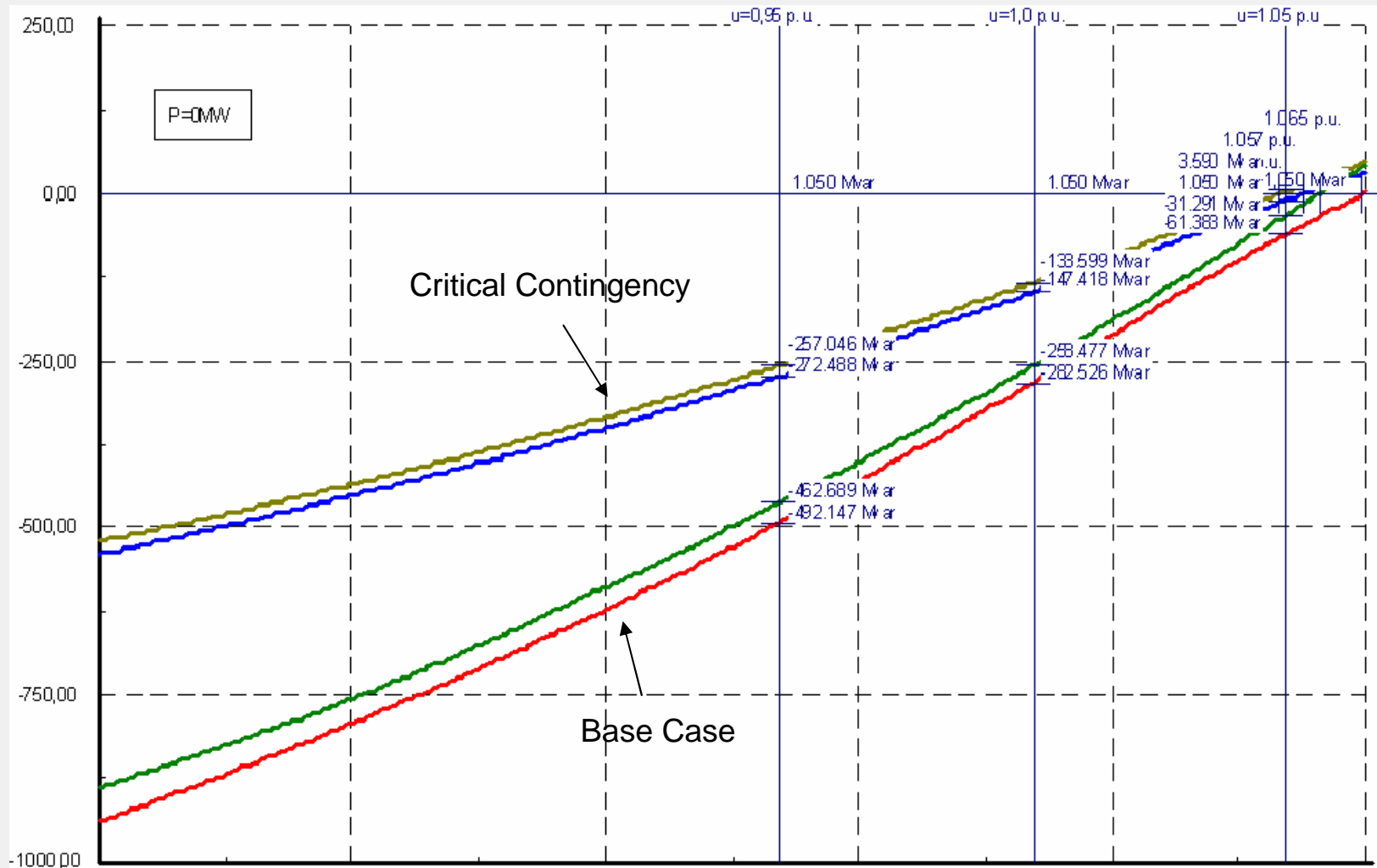



Required Reactive Range (P=0MW)

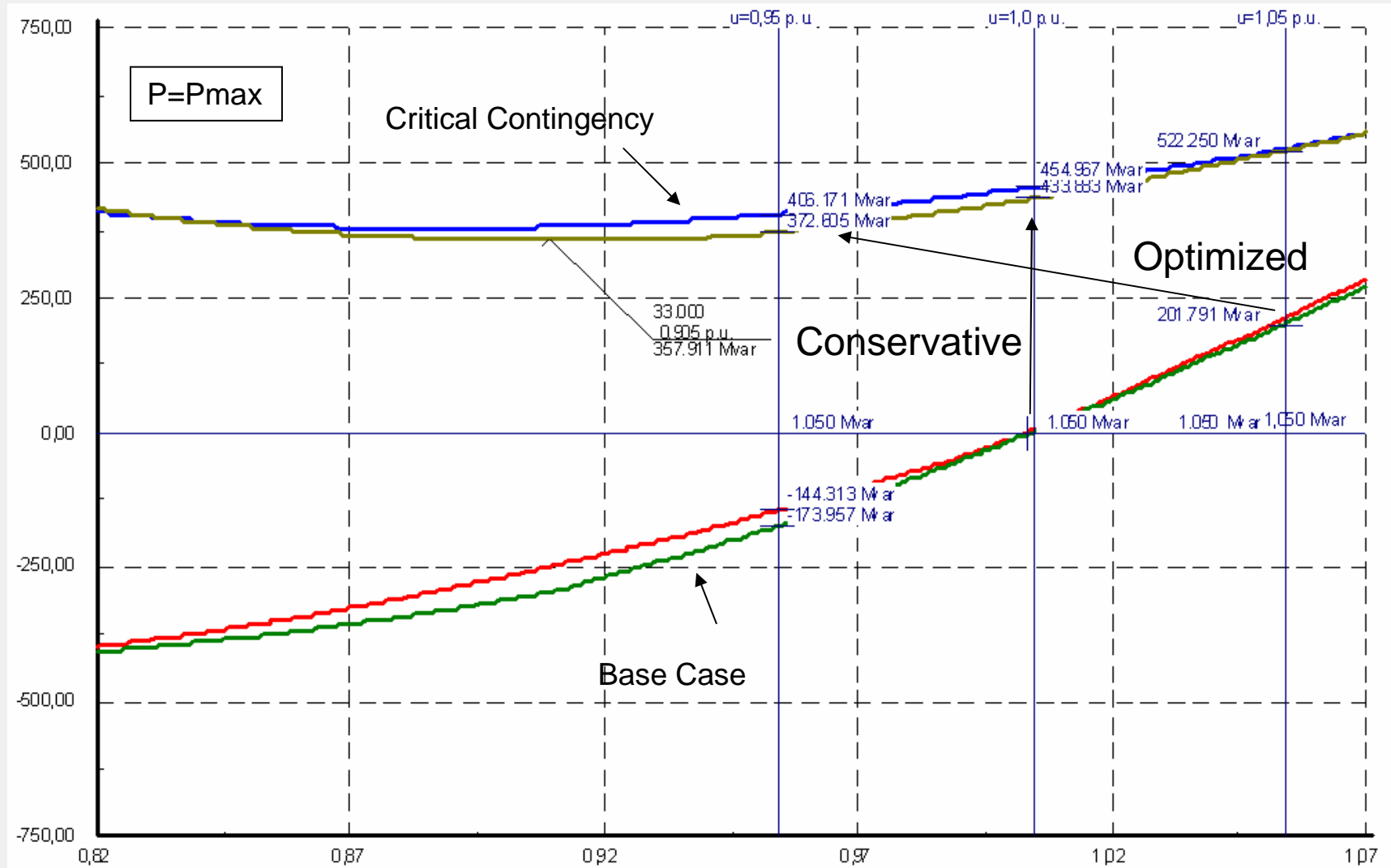

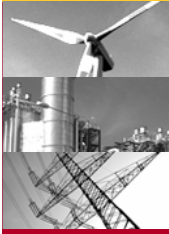

Required Reactive Power Range

- Voltage control (with feed-back) required for ensuring voltage stability.
- Droop control can reduce the required reactive power range.
- Conservative Approach (maintaining the voltage):
 - $Q_{svc} = \pm 230 \text{ Mvar}$
- Non conservative approach (using the full permitted voltage range):
 - $Q_{svc} = \pm 110 \text{ Mvar}$
- -> Verification of short-term voltage stability required



Short-Term Voltage Stability: Optimized SVC Size

- $Q_{svc} = +/-110$ Mvar
- Max. dynamic range
- -> Unstable!
- Reduction of var-provision of wind farm in case of low voltages (shunt capacitor)

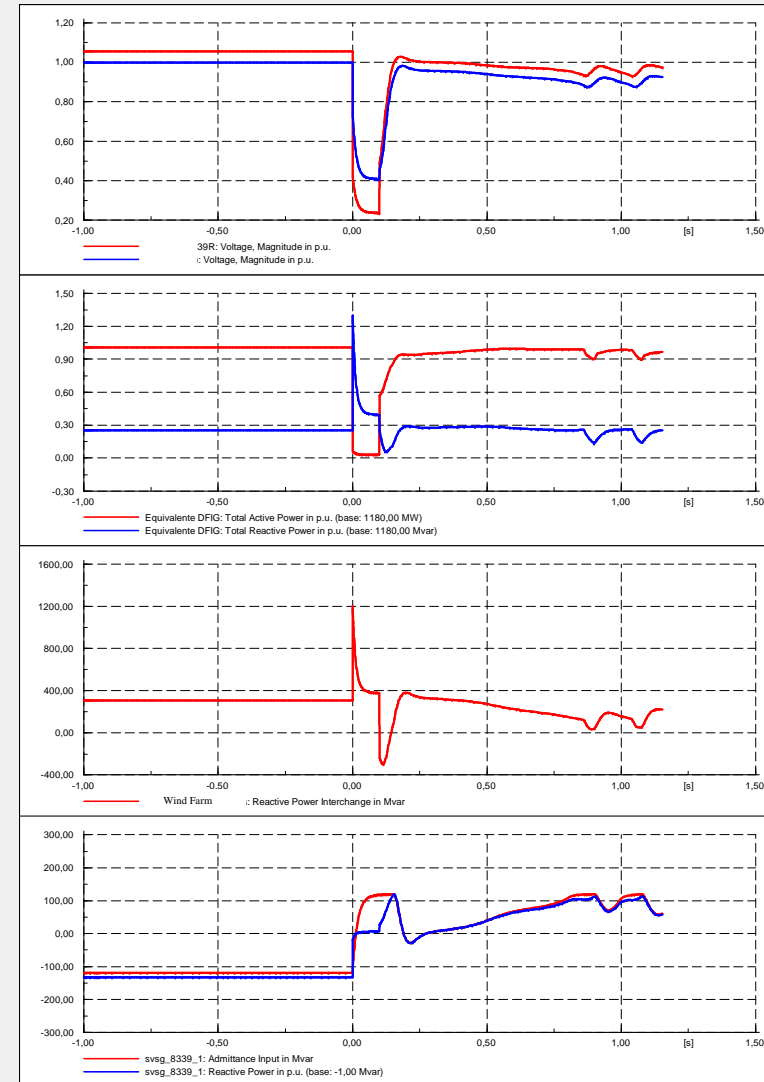

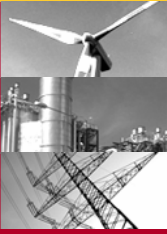

Short-Term Voltage Stability: Conservative SVC-Size

- $Q_{svc} = +/-200$ Mvar
- max. dynamic range
- -> Stable

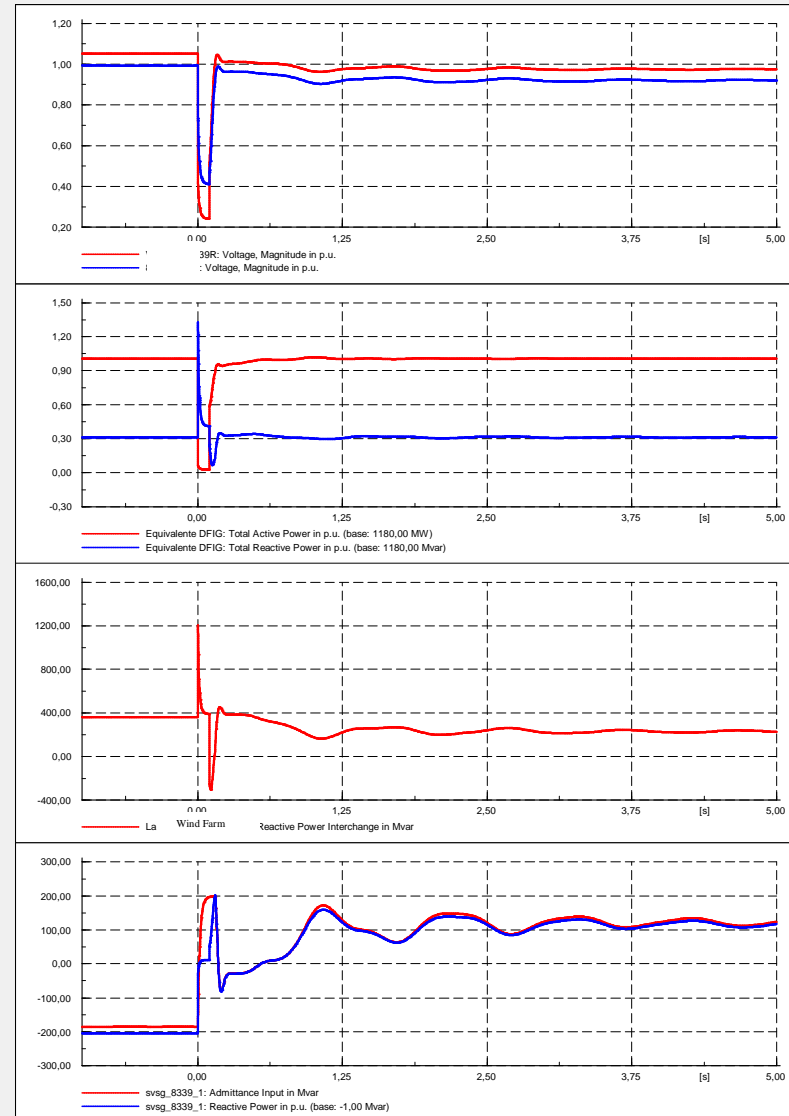



Voltage Stability at Grid Connection Point - Summary



- When connecting wind farms to the grid via very long AC lines, voltage stability at the grid connection point must be maintained by the wind farm reactive power control capability
- Wind Generators can control reactive power. However, distance to grid connection point may be large in some cases
- Proposed Solution for maintaining voltage stability:
 - Combination of SVC and
 - Reactive power capability of wind farms
- WTGs: „Slow“ reactive power control (Reactive power „dispatch“)
- SVC: Provision of dynamic var-reserve
- Verification of short-term voltage stability is essential!



Local Stability Effect of Wind Generation - Summary

gtz

SILENT
DIG

- Variable speed wind generators don't show any classical rotor angle stability problem (WTGs don't swing...)
- FRT-capability must be ensured for avoiding disconnection of wind farms in case of faults.
- In case of long AC-line connections, voltage stability at the grid connection point must be maintained by the WTGs+additional dynamic var-compensation (SVC, STATCOM)
- Identification of required slow and fast var-range by QV-curves and dynamic simulations.



Power System Stability – Global vs. local stability

Local effects:

- Loss of synchronism of an individual generator.
- „Run-away“ condition of induction generators.
- Trip of wind generators due to voltage sags.
- Voltage stability at the wind farm connection point

Global effects:

- Loss of synchronism between network areas -> islanding
- Inter-area oscillations with insufficient damping
- Frequency drop -> excessive load shedding
- Voltage collapse -> system blackout

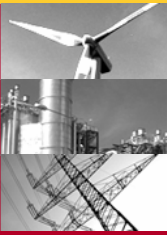

Wind Generator Impact on Inter-Regional Transfer Limits **gtz**

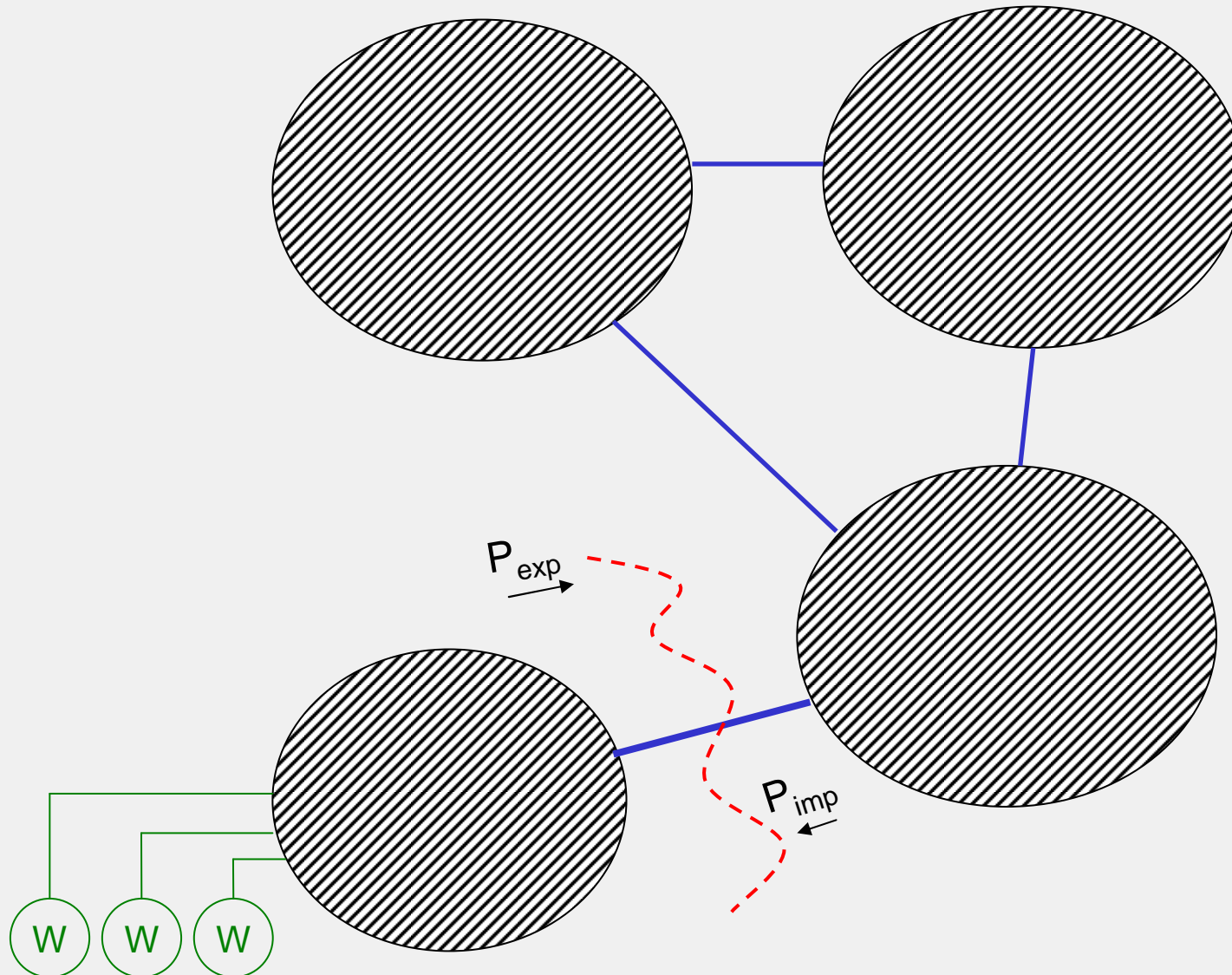



Limitation of Inter-Regional Power Transfers



Power Export:

- Thermal Limits of Tie-Lines
- Transient Stability
- Oscillatory Stability (Damping)

Power Import:

- Thermal Limits of Tie-Lines
- Voltage Stability (especially Generator Outage)
- Frequency Stability (Islanding)



Power Systems with High Level of Wind Generation

380/220kV

110kV

20/10kV

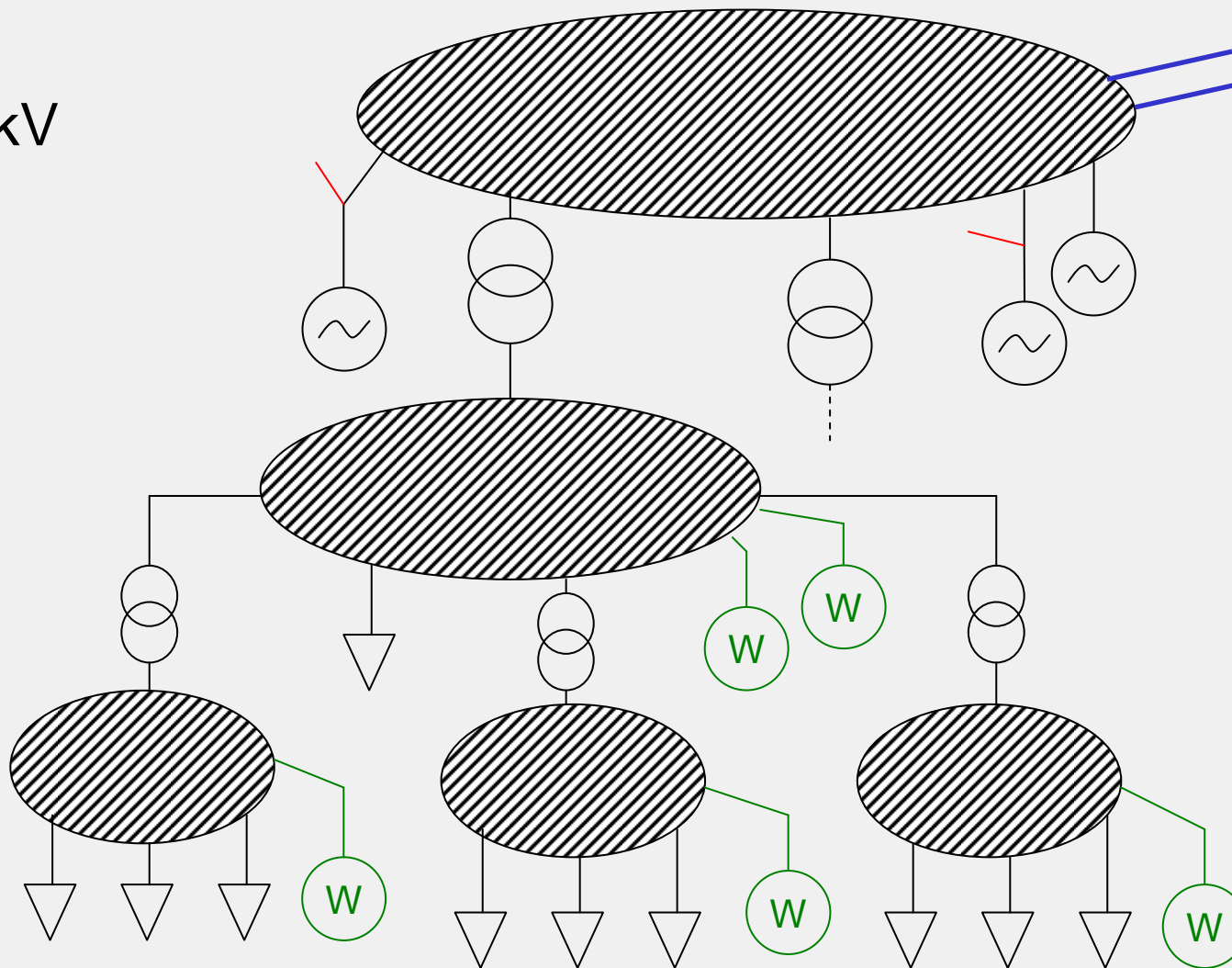

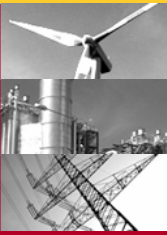

Power Export

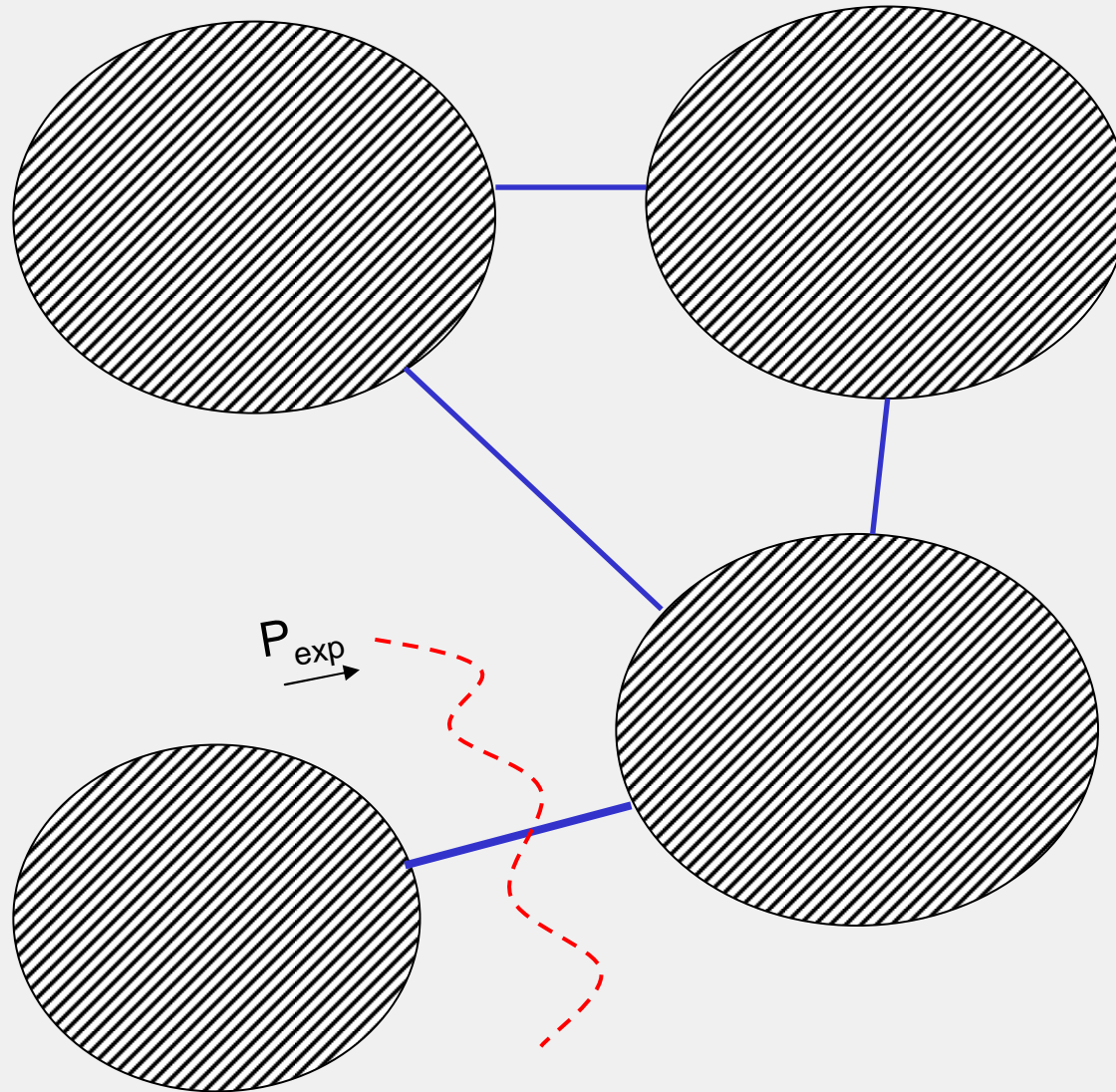

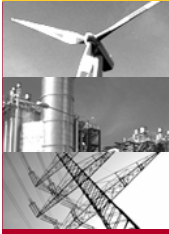

Power Export – Transient Stability

What is different with wind generation?

- Different generator technology.
- Connection to lower voltage levels.
- Larger average distances between synchronous generation.

Influence on Export-Limit?

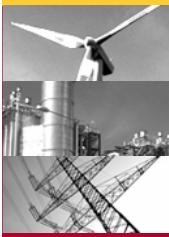

Power Export – Transient Stability

Simulation, $P_{exp}=90\text{MW}$

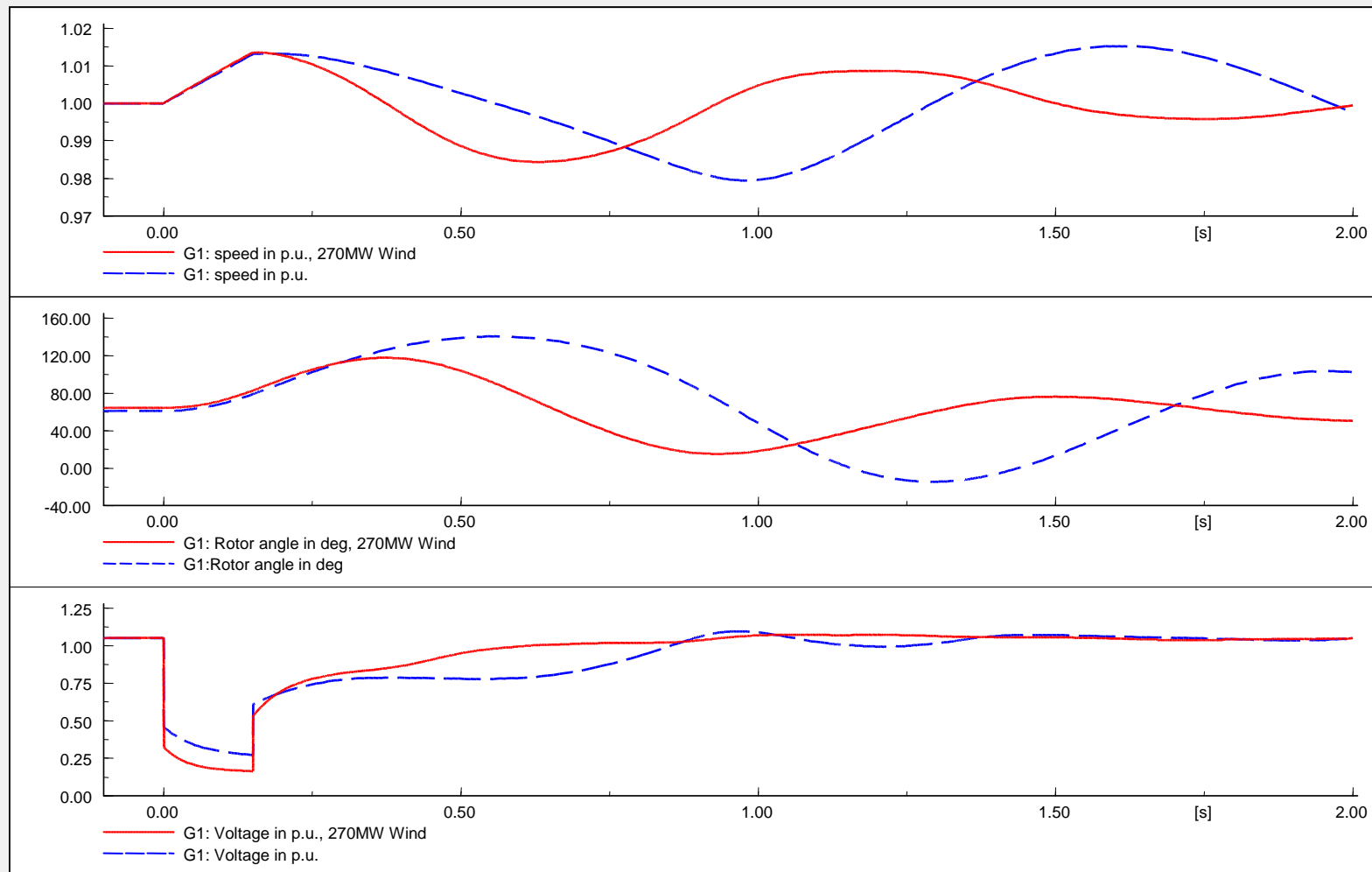



Power Export – Transient Stability

Simulation, $P_{exp}=180\text{MW}$

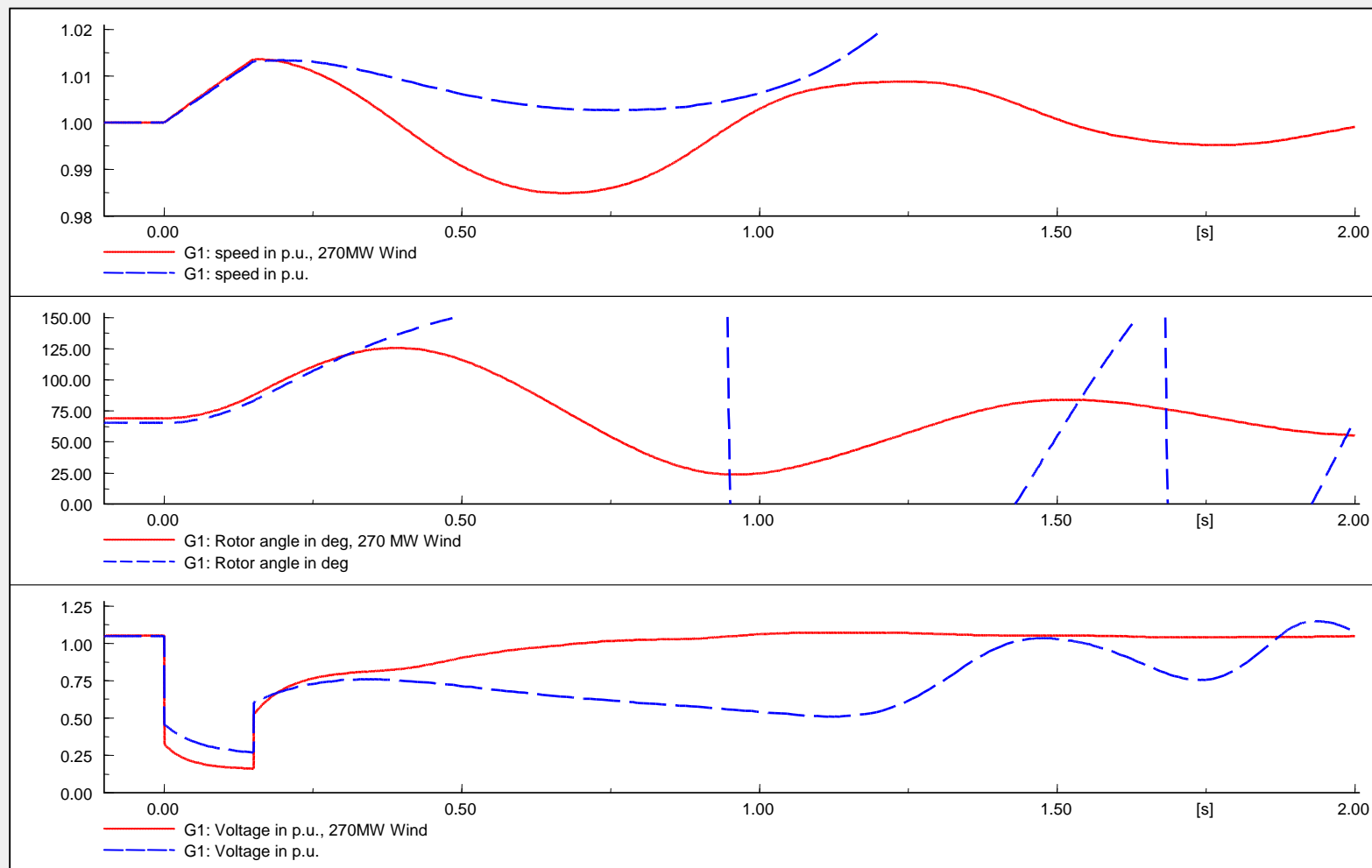



Transient Stability and Wind Power – Basic Considerations

- Wind generator modelling as „static generator“, assuming:
 - P-control
 - Q-control

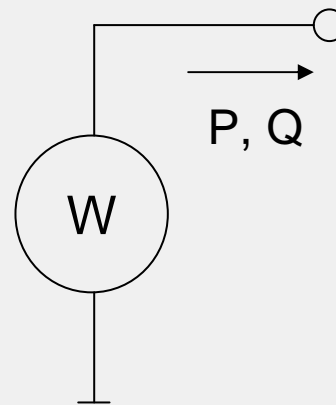

- Aggrupation of all wind generators in one region

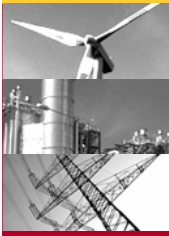

Power Export – Transient Stability

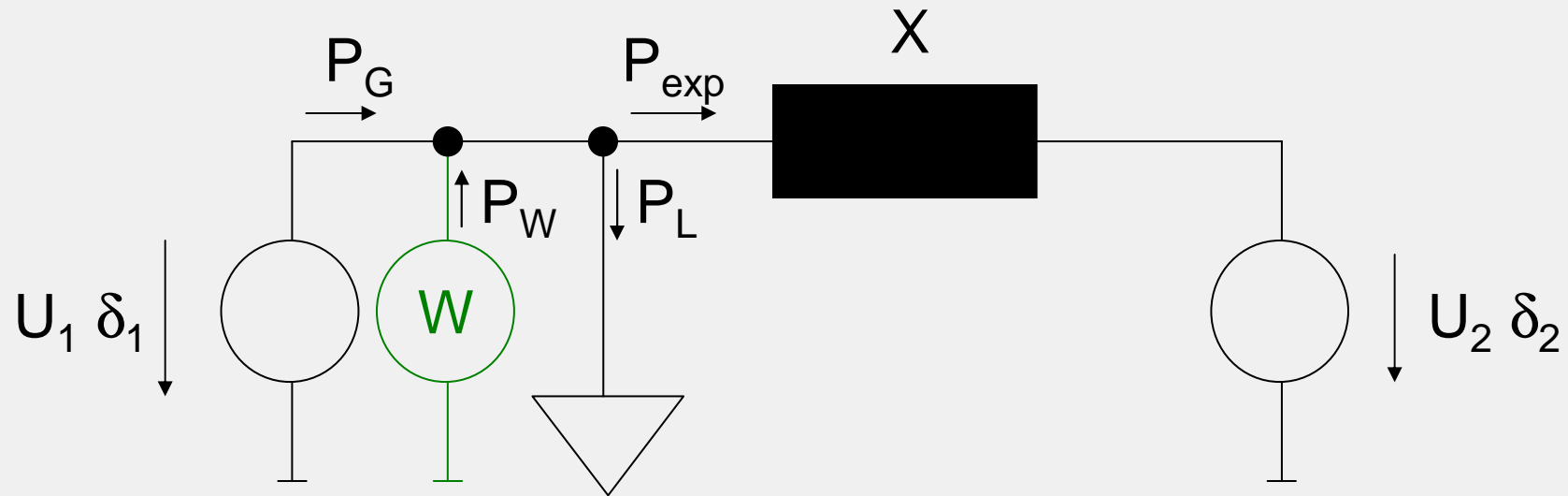

$$P_G = P_L - P_W + P_{exp} = P_L - P_W + \frac{U_1 U_2}{X} \sin \delta_{12}$$



Power Export – Transient Stability

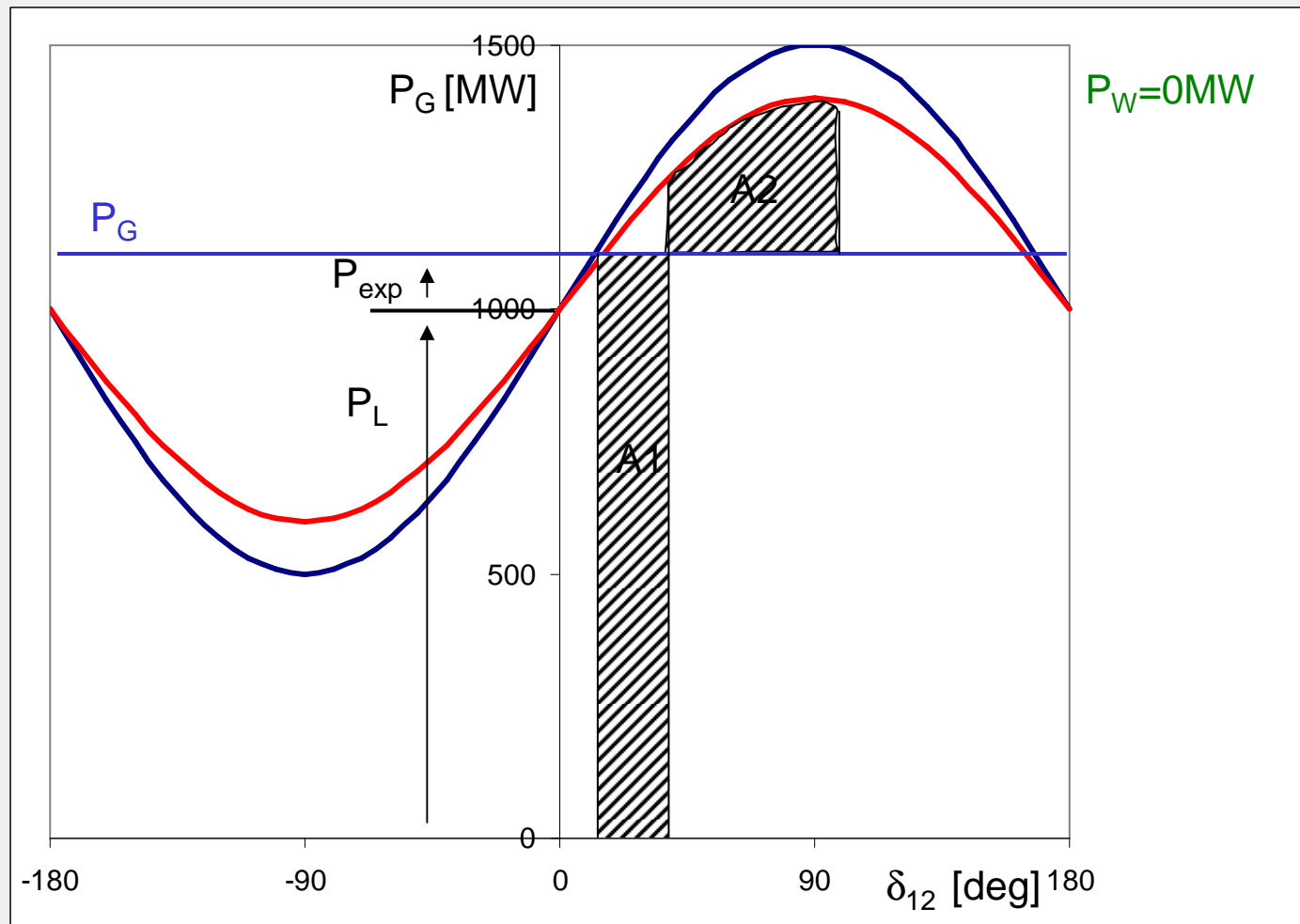



Power Export – Transient Stability

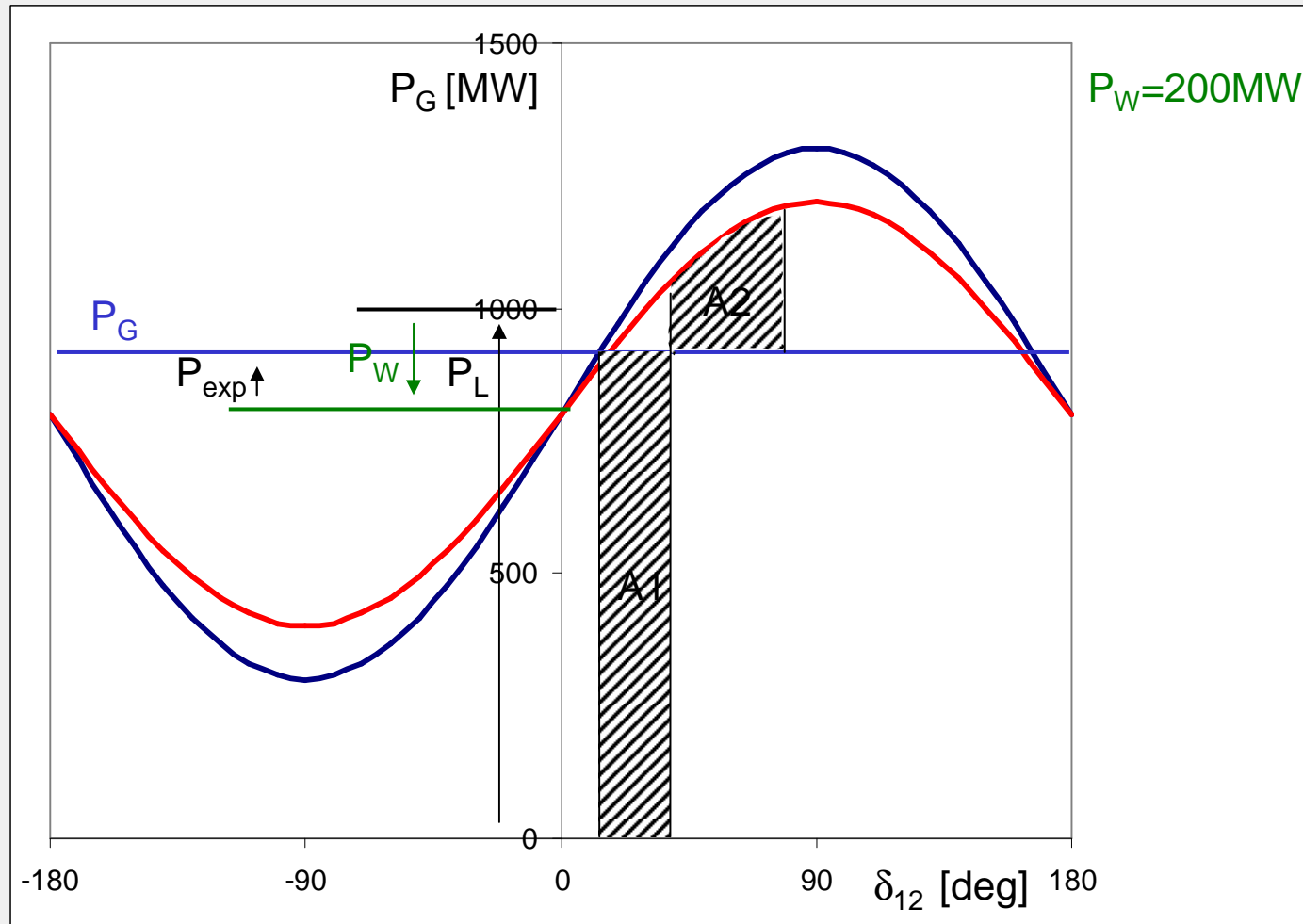

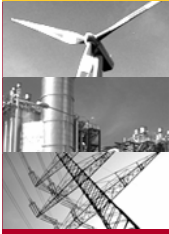

Power Export – Transient Stability

„Static“ generator technology increases transient stability limits:

- Kinetic energy is reduced because less synchronous generators are connected to the grid.
- Rotor angle deviation during fault remains almost constant because acceleration time constant referred to total synchronous generation has not changed.
- Result: area A1 small, „room“ für A2 remains unchanged -> Increase of transient stability limits.

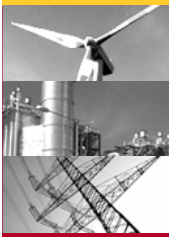

Limits of Inter-Regional Power Flows

Case 2

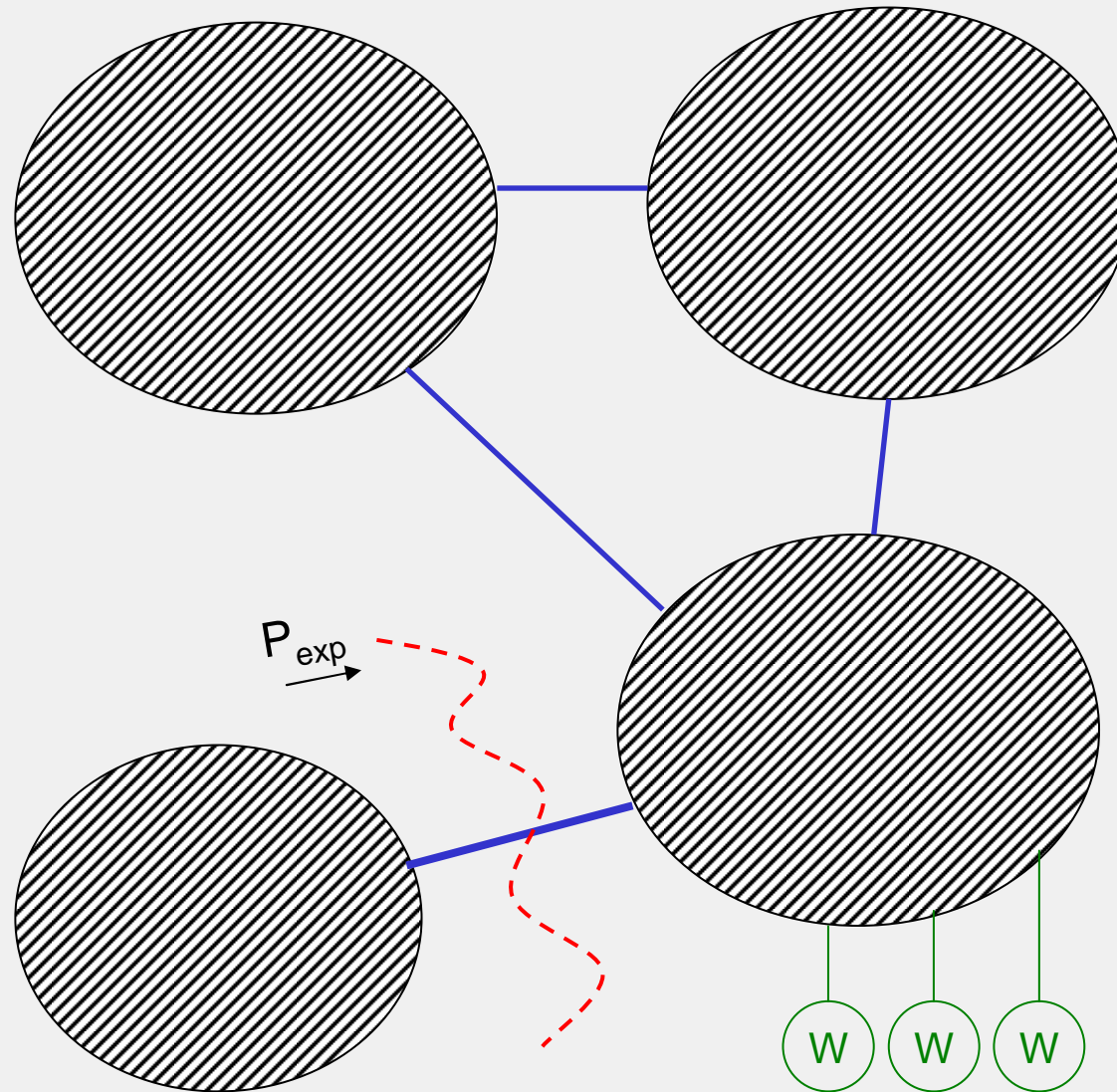

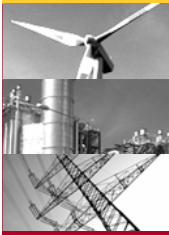

Power Export – Transient Stability

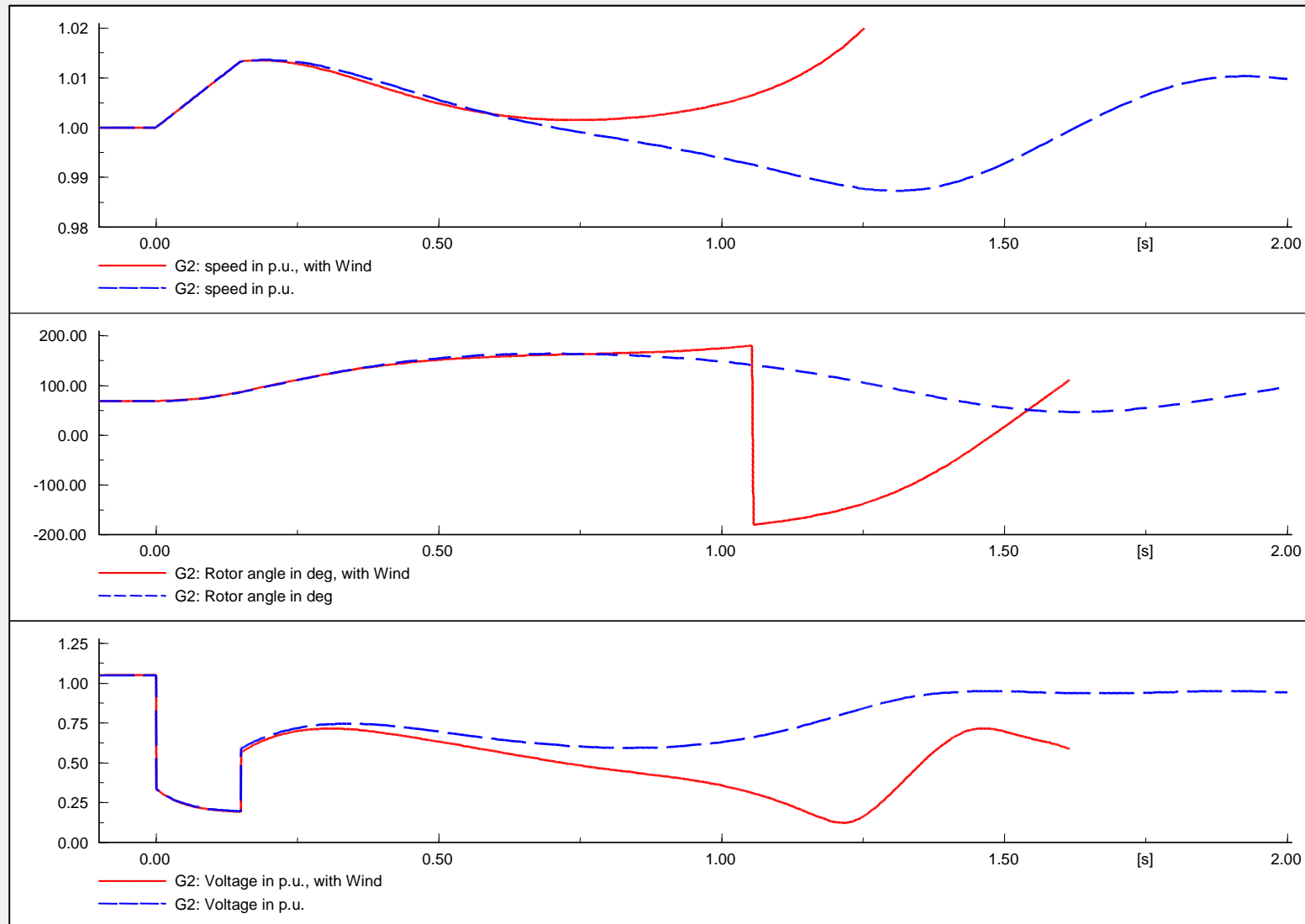



Power Export – Transient Stability

Positive:

- Lower level of kinetic energy increase during fault.
 - > Increase of transient stability export limits.
 - > Improved voltage recovery.

Negative:

- Larger voltage dip during fault.
- Dynamic reactive power reserve reduced because of missing voltage control capability and connection to subtransmission areas.
- Increase of average distance between synchronous generation, higher transfer impedances.



Power Import – Voltage Stability

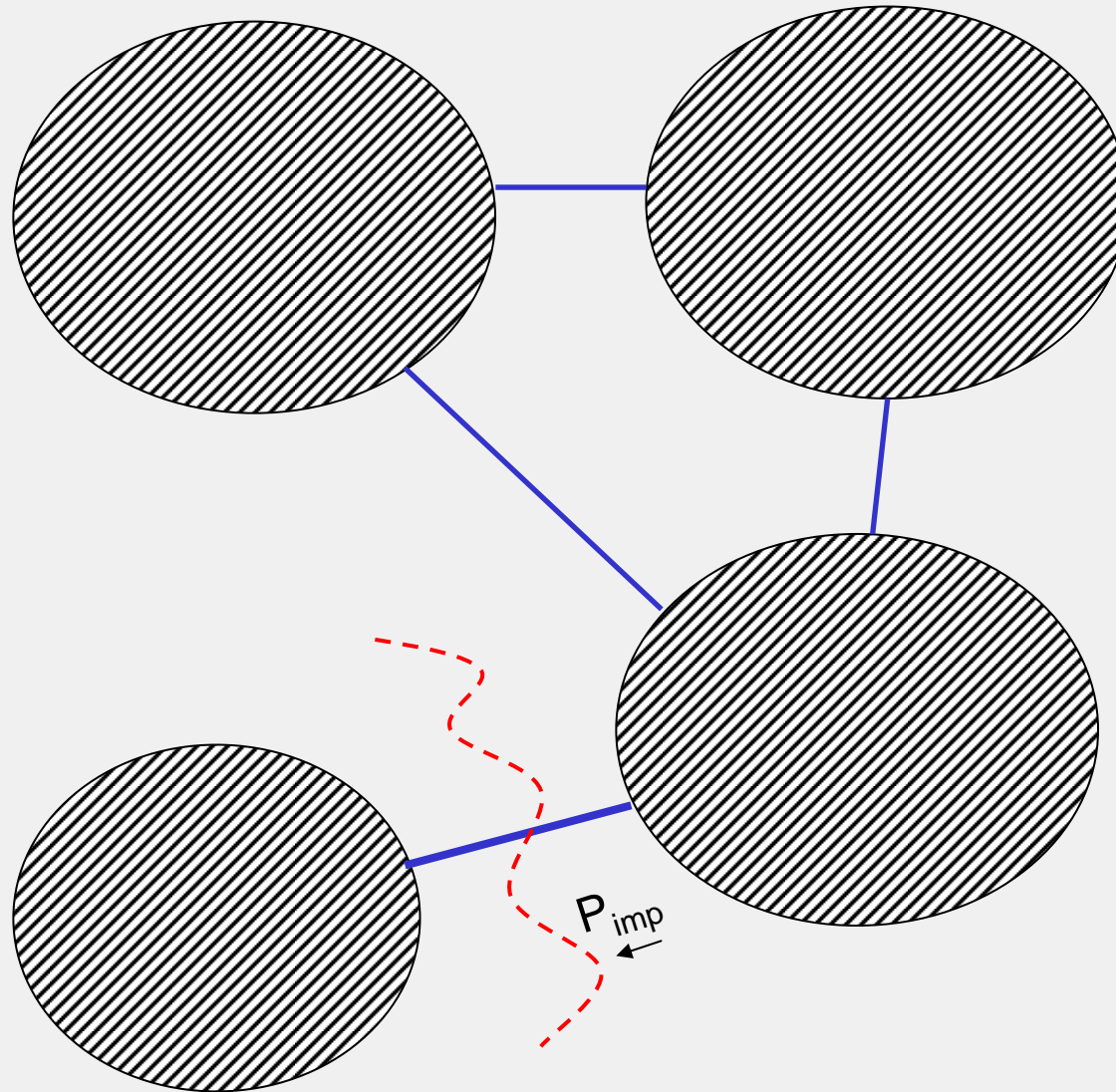



Long-Term vs. Short-Term Voltage Stability

Reactive power control:

	Short-Term	Long-Term
Q- contribution of synchronous gen.	Large (thermal overload capabilities)	Limited by overexcitation limitors
Switchable shunts	No contribution (switching times too high)	High contribution
SVC/TSC	High contribution	High contribution

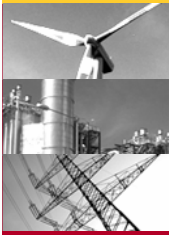

Power Import – Voltage Stability

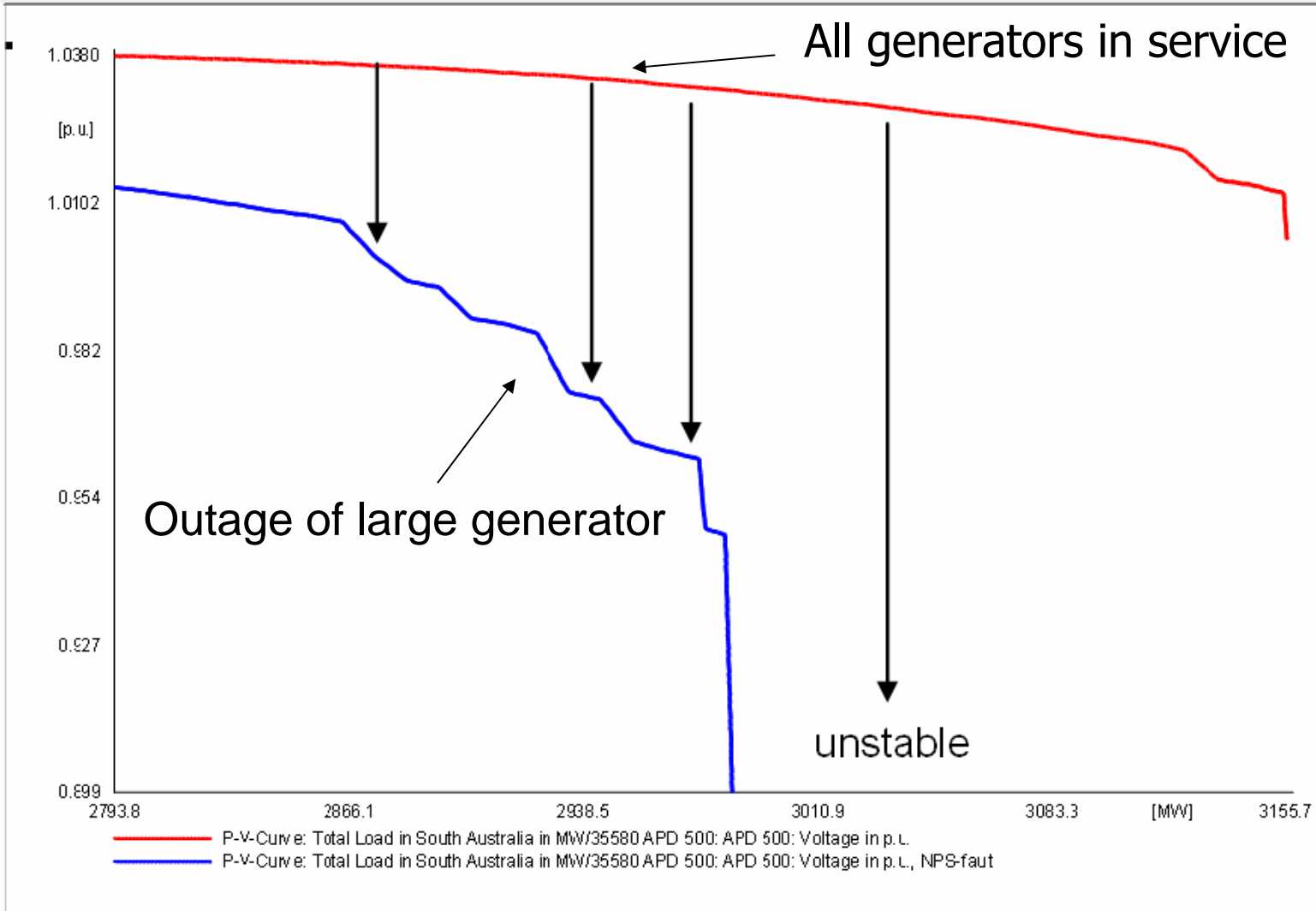



Power Import – Generator Outage

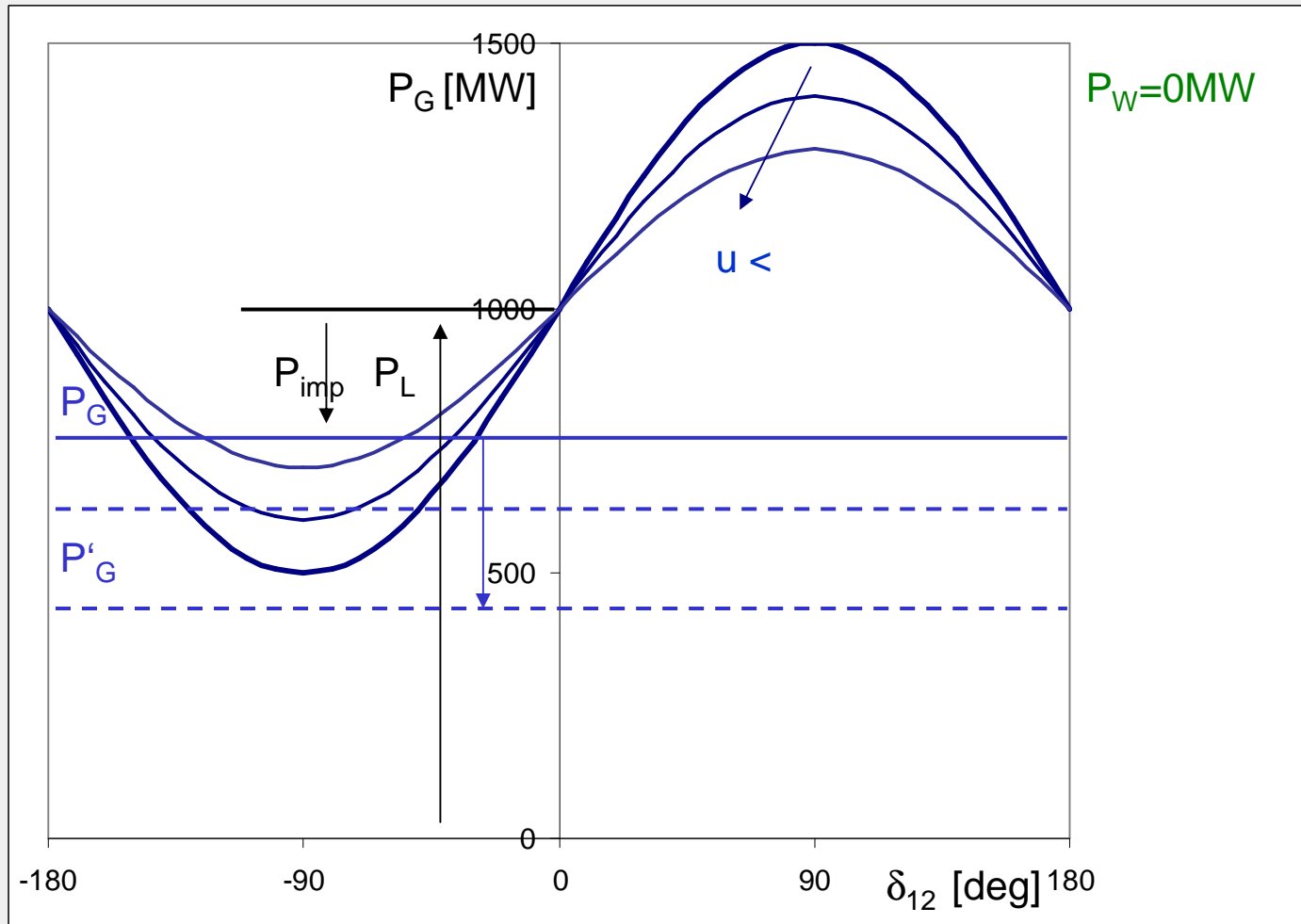

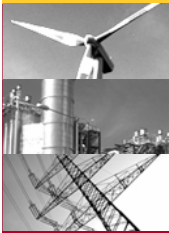

Short-Term Voltage Instability

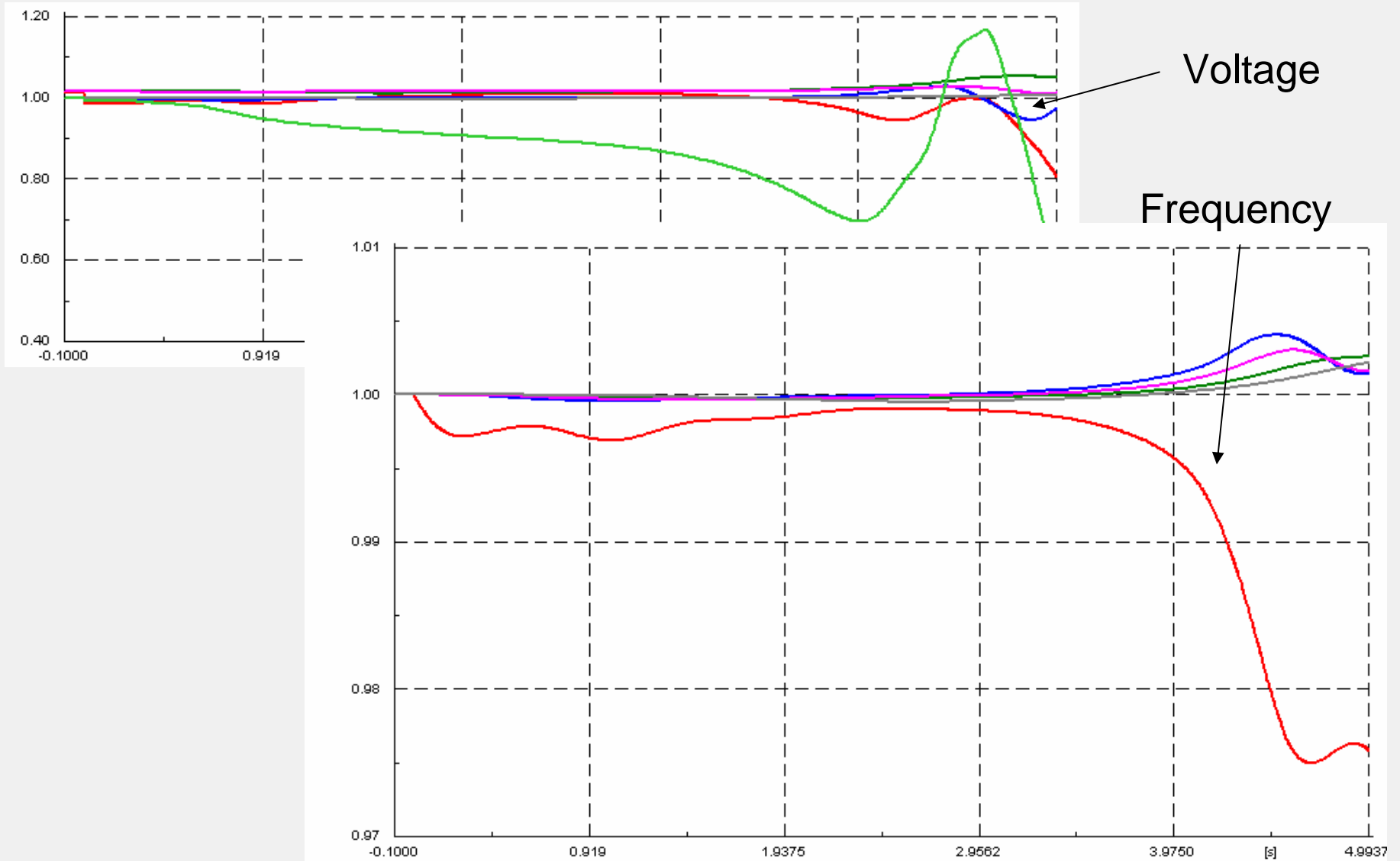



Power Import – Generator Outage – Wind Generator Impact



Wind generator impact on voltage stability:

- Basically no influence of „static generation“ on voltage stability limits.
- Reduced reactive power reserves shifts the system closer to voltage stability limits.
- Unreliable active power output of wind mills amplifies generator outage problem (cascading outages).

Power Import - Islanding

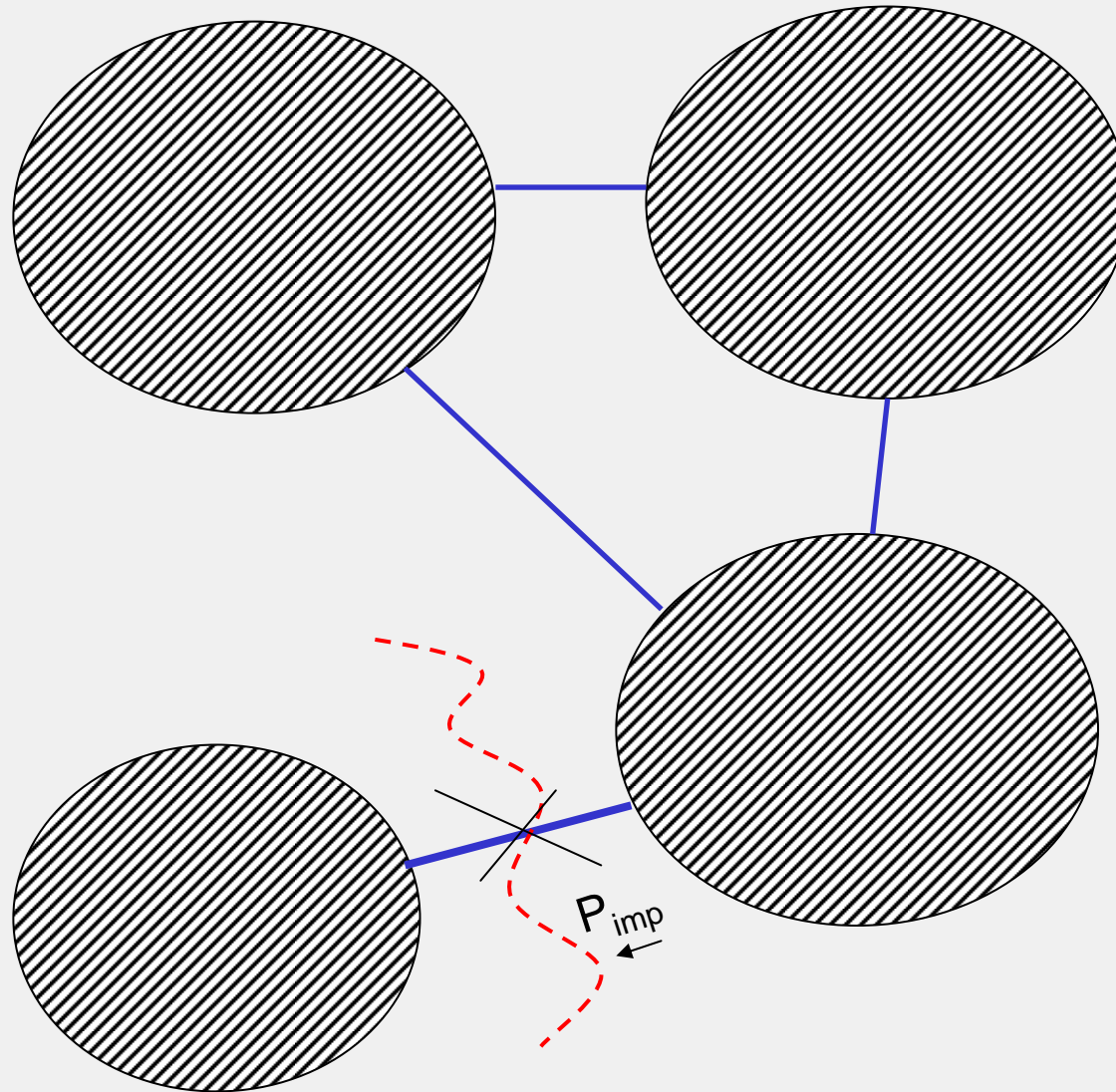

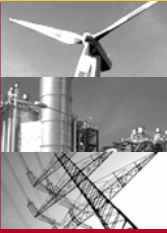

Power Import – Islanding – Frequency Stability

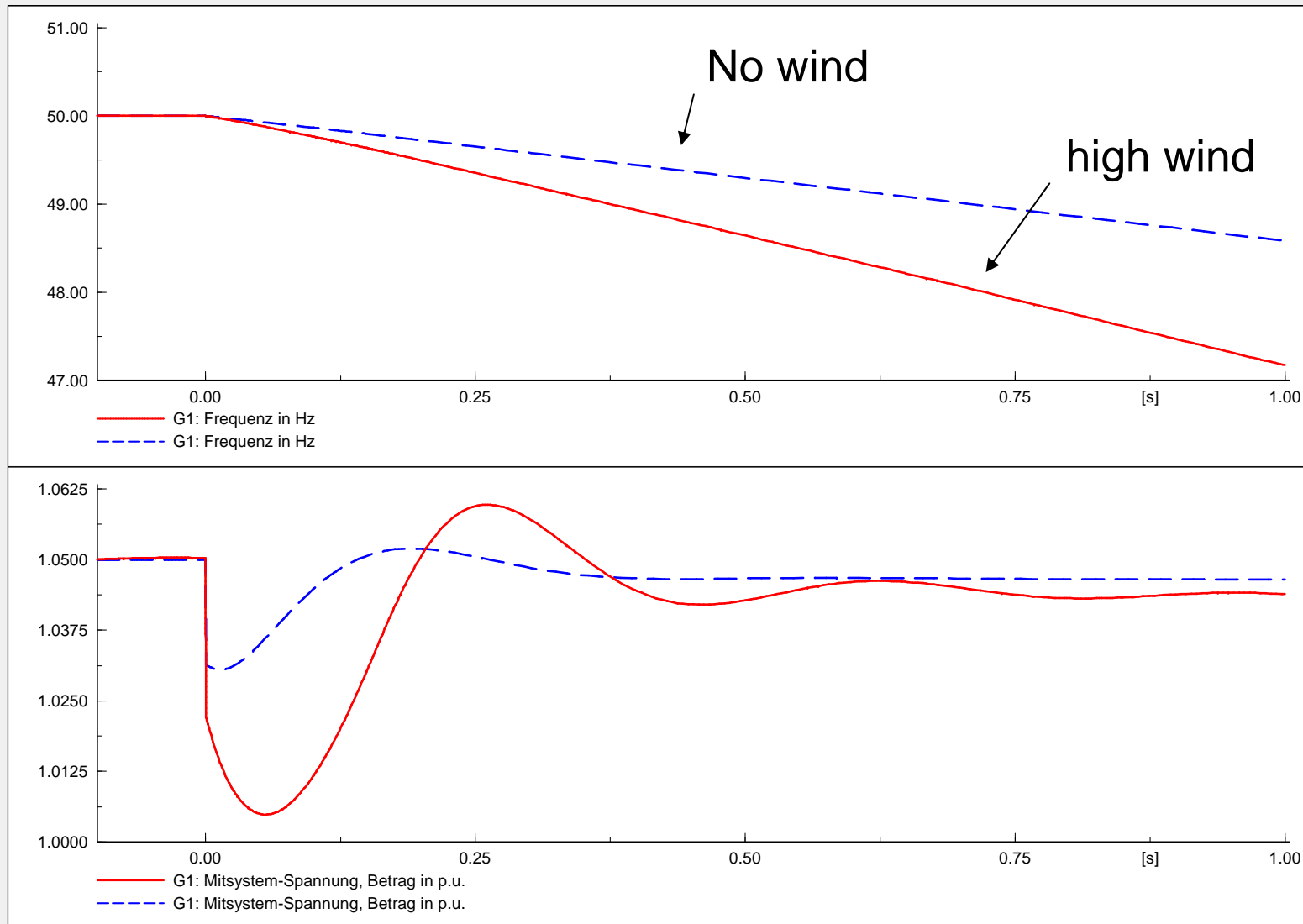

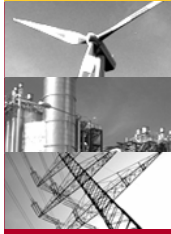

Power Import – Islanding

Islanding results in frequency stability problems ($P_{imp}=0$):

$$J\dot{\omega} = \frac{P_G + P_{imp} - P_{el}}{\omega}$$

- Total generation (synchronous+wind) remains constant.
- Inertia J reduced.
- **Consequence: Frequency drops faster -> increased load shedding**
- Possibly voltage problems because of reduced reactive power reserve in the „island“.
- **Power reduction of wind generators following to low voltages can make the situation worse.**



Wind Generator Impact on System Stability - Summary



Wind generation has:

- **Positive** influence on transient stability constrained **export** limits.
- **Negative** impact on voltage stability constrained **import** limits if:
 - Reactive reserves are lowered -> additional SVCs, SynCons required.
 - Unreliable power output -> „low voltage ride-through capability“ required
- **Negative** impact on **frequency drops** in case of islanding during power import.

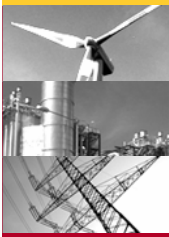

Thank You



Markus Pöller
mpoeller@digsilent.de

DIGSILENT GmbH
Heinrich-Hertz-Str. 9
72810 Gomaringen
www.digsilent.de