



Subsidy schemes for the dissemination of improved stoves

Experiences of GTZ HERA and Energising Development

Mirco Gaul
SiNERGi Renewable Energy Services

Eschborn, May 2009

On behalf of the Deutsche Gesellschaft für Technische Zusammenarbeit (GTZ) GmbH, HERA Poverty-oriented basic energy services



Acknowledgement

This study could only be prepared with the kind support of many people:

Marlis Kees, Verena Brinkman and Lisa Feldman of GTZ/HERA provided important background information and documents on the program for household energy and sustainable development.

For the different case studies Moussa Doumbia, Antene Gulelat, Klas Heising, Benoit Legong, Andrea Reikat and Hiwote Teshome supported the project analysis providing key documents and patiently answering the numerous detail questions.

Content

1. Introduction.....	5
2. Dissemination of improved stoves.....	6
2.1 <i>Applied subsidy schemes.....</i>	7
2.2.1 Direct subsidies	7
2.2.2 Indirect subsidies	7
2.2.3 Pros and cons of direct and indirect subsidies	8
2.2.4 Smart subsidies	9
2.2 <i>Dissemination Models</i>	10
2.2.1 Non-commercial stove dissemination.....	10
2.2.2 Market building for disseminating stoves commercially	10
3. Analysis of the country examples	11
4. Country Example	16
3.1 <i>Bolivia - PROAGRO/EnDev Bolivia</i>	17
3.1.1. Strengths, challenges and lessons learnt.....	18
3.1.2. Infobox Bolivia	19
3.1.3. Subsidy scheme Bolivia.....	20
3.2 <i>Burkina Faso - Foyers Améliorés au Burkina Faso (FAFASO)</i>	21
3.2.1. Strengths, challenges and lessons learnt.....	21
3.2.2. Infobox Burkina Faso.....	23
3.2.3. Subsidy scheme FAFASO	24
3.3 <i>Ethiopia - SUN-E/EnDev Ethiopia.....</i>	25
3.3.1. Strengths, challenges and lessons learnt.....	25
3.3.2. Infobox Ethiopia	27
3.3.3. Subsidy scheme Ethiopia	28
3.4 <i>Mali - Foyers Améliorés au Mali (FAMALI)</i>	29
3.4.1. Strengths, challenges and lessons learnt.....	29
3.4.2. Infobox FAMALI	31
3.4.3. Subsidy scheme FAMALI	32
5. Literature	33

Glossary

APCMM	- Malian Craftsmen association (L'Assemblée Permanente des Chambres de Métiers du Mali)
AMADER	- Malian Energy Agency (Agence Malienne pour le Développement de l'Energie Domestique et de l'Electrification Rurale)
CILSS	- (Burkina Faso)
CNESOLER	- National Centre for Solar and Renewable Energies (Mali)
CPC	- Stove testing centre (Bolivia)
EnDev	- Energising Development – Dutch German Partnership Program
EREDPC	- Ethiopian Rural Energy Development and Promotion Centre
FAMALI	- Foyers Améliorés au Mali
FAFASO	- Foyers Améliorés au Burkina Faso
HEURA	- Household Energy and Universal Rural Access Project in Mali financed by World Bank
HEPNR	- Household Energy Protection of Natural Resources (GTZ-Ethiopia)
IRSAT	- Institut de Recherche en Sciences Appliquées et Technologies (Burkina Faso)
LPG	- Liquefied petroleum gas
MDG	Millennium Development Goals
MFI	- Micro Finance Institution
NGO	- Non Governmental Organisation
SPM	- Sustainable Production Maximum
SUN-E Program	- Sustainable Utilization of Natural Resources for Improved Food Security Program (GTZ-Ethiopia)
PEDASB	- French abbreviation for the World Bank HEURA Project
PREDAS	- Regional Program for Household Energy Promotion in Sahel Countries
VAT	- Value Adding Tax

1. Introduction

This study aims to give a short overview of the current state of approaches and strategies for the promotion of improved stoves by GTZ and its programme Energising Development. Therefore some recent experiences of four stove projects in Bolivia, Burkina Faso, Ethiopia and Mali are reviewed focussing on the role of subsidies.

Chapter 2 shortly introduces the issue of subsidies for the promotion of improved stoves. After describing the different types of direct and indirect subsidies, it summarises the pros and cons in the current debate on direct subsidies and introduces the term of smart subsidies.

Chapter 3 compares the most relevant characteristics of the 4 country examples in terms of dissemination models, subsidy schemes, costs of dissemination and stoves as well as the share of direct and indirect subsidies.

Chapter 4 presents examples from various countries. After a short presentation of the projects' goals and key activities, each project is described according to the following structure:

1. The most important strengths, challenges and experiences of the project are summarised.
2. In an info-box all relevant information on the project is systematically described.
3. For each project a chart illustrates the activities and finance flows involved in the dissemination of one improved stove.

The study provides a quick overview to understand and compare different approaches and strategies which promote and subsidise stoves. It gives a basis for looking at the experiences others had with their projects, in order to exchange strategies and lessons learnt.

The short and focussed scope of the study limits the space for a more detailed or in depth discussion of specific circumstances or different framework conditions. The comparison is therefore not to be understood as a benchmark as relatively higher costs per stove disseminated may reflect the specific challenges a project had to face; the presented results therefore rather intend to prepare the ground for a fruitful debate.

2. Dissemination of improved stoves

In many developing countries, traditional cooking fuels like wood, dung or charcoal still dominate in rural as well as in peri-urban and urban areas. The rationale for the promotion of improved stoves follows two objectives: the prevention of indoor air pollution and the efficient use of scarce resources. The first time, the traditional cooking sector had been explicitly targeted after the first oil shock in the mid 1970s. At that time energy sector and resource analysis stated the so-called 'woodfuel crisis', assuming a classic dilemma of growing demand outstripping the fuelwood supply and consequently causing a fuelwood consumption at unsustainable rates. After two decades of debate updated data analysis disproved the 'woodfuel gap' theory¹. Since the adoption of the Millennium Development Goals (MDG) the danger of indoor air pollution especially for the health of women and children has been highlighted by the WHO and others, providing the issue of improved cooking stoves with new momentum.

However, since the 1980s a large variety of activities by multinational donor organisations, governments and NGOs addressed both, supply and demand side of the fuelwood problem. On the supply side afforestation programmes aimed to increase the forest areas, while on the demand side home-size biogas plants and improved stoves have been disseminated in huge quantities. Both approaches encountered different barriers. The demand side perspective of stove dissemination will be shortly described in the following paragraph.

For a sustainable dissemination of improved cooking stoves a number of barriers have to be overcome which in one or the other way all deal with the problem of access and sustainability. While market oriented interventions typically stumble on market barriers to develop and introduce a new and affordable product in a weak market environment (especially in rural areas), non-commercial approaches struggle with a long-term viability of maintenance and replacement of free-given or self-produced stoves.

In this framework, subsidies play a crucial role to overcome these barriers by supporting a sustainable market development or by cross-subsidising basic infrastructure in rural structurally weak areas. Several typical areas which are targeted by direct or indirect subsidies can be distinguished:

1. Demand and socio-cultural framework: Cooking is highly cultural sensitive and cooking habits cannot easily or quickly be changed. The assessment and reflection of local expectations and requirements is vital for a successful product development.
2. Technology: Research and development for improved cooking stoves will normally exceed the capacity of small producers, as balancing high quality with a local producible design and low product cost involves expensive engineering capacity.
3. Awareness: The benefits of improved stoves have to be understood by the whole household as decisions are often not made by women and children which suffer most from smoke or arduous fuelwood collection.
4. Supply & Marketing: The set-up of effective product service chains and endogenous marketing requires a strong capacity and skill training of involved actors.
5. Financing: High efficient but expensive stoves (e.g. for peri-urban areas with fuel costs) depend on the availability of microfinance, while even MFIs (micro finance institutions) and stove producers may require credits.
6. Policy: For a long-term success the public sector should be involved. Regulation and sector policy should be coherent and supportive (technical standards, tax and customs).

¹ "Beside the ignorance of agricultural expansion, which has been responsible for up to 70 % of forest cuttings, a misconception of woodfuel resources caused the wrong predictions. Mainly forestry plantations and natural forest areas have been counted by statistics, but woodfuel is more often collected from open woodlands and trees around homesteads, along road sides, within villages and on agricultural land." See WEC/FAO 1999, p50/51

2.1 Applied subsidy schemes

As with many other products, the array of subsidies for stove dissemination is extensive, and their use is hotly debated among those working on cooking energy². There is general agreement that a purely market-driven approach to dissemination of improved stoves in rural areas without established markets poses a challenge. The high risk and consequently high financing costs of introducing products into remote markets can lead to prohibitive stove prices. Since existing fuel markets in these locations consist mainly of woodfuel (collected at no monetary cost), and kerosene or LPG (which typically is subsidised already), there is little economic motivation for households to buy an improved stove. So the debate is not about whether to use or not use improved stoves at all, but rather how they can be used best.

There are two approaches to subsidies for stove dissemination:

1. The use of direct subsidies to bring down the selling price of stoves (partially or totally)
2. The use of indirect subsidies to help establish a market through activities such as subsidised training, product promotion, and awareness creation

The essential question for both these approaches is how to make subsidies that are both fiscally sustainable, and that lead to a rapid increase in market uptake (with subsequent improvements in costs, performance, and supply chain reliability).

2.2.1 Direct subsidies

Direct Subsidies typically involve a direct cash transfer to the stove producer or consumer. Various types of direct subsidies are described as follows:

- Buy down grants to reduce the product price directly. There are different approaches to channel a buy down grant, such as paying the producer for every system sold or installed, or providing the money (or an equivalent voucher) directly to the customer. The extreme form of a buy down grant would be a 100% subsidy of the consumer price (an approach often used in the health sector).
- Start up grants and/or soft loans to support the setting up of production and marketing infrastructure for a stove producer. To start up new (or to extend existing) businesses to rural areas often includes a high primary investment in infrastructure, staff and marketing, with high risks and transaction costs. Start up grants or long-term loans with low interest rates spread out the initial financial burden for stove producers.
- Custom reductions for imported stoves (and components), and tax reductions for stove producers or fuels. A few improved stoves require imported high technology components, though this is less common than for other renewable energy technologies (e.g. solar home systems). Their added value will mostly take place in their country of origin, so there is little scope for custom exemption. Income tax and value-added tax reductions for stove producers are an option during the start up period. Tax reductions on many fossil fuels, such as LPG or kerosene, have a much greater influence.

2.2.2 Indirect subsidies

Indirect subsidies refer to public financing that reduces the price to the consumer, but not through a direct cash transfer. The most frequent types of indirect subsidies for improved stoves are:

- Public awareness and product promotion campaigns for increasing public understanding, and thus increasing the demand for improved stoves. This awareness could be about indoor air pollution alleviation and the subsequent

² A good example is the recent debate reported on the HEDON Household Energy Network. <http://www.hedon.info/goto.php/CleanAirSIG:Subsidies>

reduction in respiratory diseases, or the cost reduction potential of efficient cooking technologies.

- Introduction of standards and certification systems that increase the product image and give the customer a certain guarantee about quality. During set-up and introduction of such a system, external support is important. In the longer term, an established market can finance certification and quality systems without external support.
- Support of microfinance institutions (MFI) can bridge the gap between the stove price and what people can afford by providing micro credits to stove customers. In some cases, MFIs might not cover the total target area, or might not have sufficient resources for large numbers of new customers, they could be supported with start up grants to extend their infrastructure, or by refinancing with soft loans, to extend their portfolio.
- Training and capacity building is one of the most frequently used types of indirect subsidies. It can include business, technical and administrative training – in most cases given free of charge, and providing support to stove producers, financing institutions, NGOs, local government and certifiers.
- When support to research and development for improved stove technologies uses public finance, this indirect subsidy is not recouped in the final product price.

2.2.3 Pros and cons of direct and indirect subsidies

While there exists a certain agreement on the positive effects of indirect subsidies for establishing a market, the use of direct subsidies is more controversial. The following key questions need to be addressed by those wanting to use subsidies: 'Should I avoid direct subsidies or use them to reduce the consumer price of fuels or technologies?'; 'Should they be partial or full subsidies? And should they be temporary or permanent subsidies?'

On the one hand direct subsidies are promoted for the following reasons:

1. Market failure: Economic theory demonstrates that several requirements have to be fulfilled for markets to function effectively³. In practice, these conditions may not exist in regions where stoves are being disseminated. Using this argument, subsidies are justified when there is:
 - Asymmetric information: People are not aware of indoor air pollution and its consequent risks for health, and they lack sufficient information about costs and savings when using improved stoves.
 - Insufficient market power: Market failure both on demand and supply side, as the existing effective demand might be insufficient to overcome the transaction costs for a market driven supply chain.
 - External effect on the public good: Indoor air pollution makes respiratory diseases more likely and advancing deforestation and desertification reduce the available firewood resources. Because these external effects increase health and environmental expenditures, the state takes responsibility and interest to protect the public goods of health and environment.
2. Poverty targeting: Direct subsidies can significantly increase the use of a cooking technology or fuel, particularly by the poorest strata of the rural population. For example in Brazil, subsidised LPG reaches 98% households, including 93% of rural households, at a cost of slightly less than US\$60 per year per low-income household. It has been stated that there is a benefit to many of those living in

³ Perman, R. (2003). Natural resource and environmental economics. Harlow, England: Pearson Addison Wesley. p 124: "... for markets to produce efficient allocations, it is necessary that: (1) Market exist for all goods and services produced and consumed; (2) All markets are perfectly competitive; (3) All transactors have perfect information; (4) Private property rights are fully assigned in all resources and commodities; (5) No externalities exist; (6) All goods and services are private goods. That is, there are no public goods; (7) All utility and production functions are 'well behaved'; (8) All agents are maximisers."

poverty even if direct subsidies are abused, and that these benefits at least match the costs lost by abuse.

3. Transparency: Direct subsidies are more transparent than indirect subsidies

On the other hand direct subsidies are criticized for the following reasons:

1. Inhibiting market development: When direct subsidies (particularly 100% subsidies) are applied, beneficiaries expect that the product will continue to be given away in future. This undermines a sense of ownership by the customer, and devalues the economic value of the item on both supply and demand sides. This undermines commercial activities and inhibits a sustainable market.
Cooking technologies and fuels are not basic health-related goods in the same way as drugs or mosquito nets. The adoption of an improved stove depends on its quality, and on its image as a modern, useful and efficient device, rather than the user's capacity to pay for it. A free widely-distributed product could well be perceived as inappropriate and be sold on for profit, or not used at all.
2. Targeting and abuse of subsidies: In some cases, direct subsidies are abused, for example, when stoves are bought for a subsidised price, but instead of using them, they are sold in other regions for a higher price.
3. Non-transparent costs: The additional transaction costs of direct subsidies are substantial and often underestimated. The costs are difficult to foresee and to assess, e.g. target setting and policy development for the subsidy, voucher systems development, identifying beneficiaries and deciding on their eligibility (this might need to be decided on a daily basis as their status may be changing constantly), and monitoring the effects of the subsidy. This kind of additional costs may not justify the expected benefit.
4. Political abuse: The distribution of partially or fully subsidised items to low income households is often exploited by political parties to rally for the election of their party. Targeting sometimes becomes distorted by political influences, as observed in Malawi with food aid, and boreholes.

There is no clear answer as to whether subsidies, and in particular direct subsidies, should be used or avoided. The question must be answered individually for every case, assessing the specific circumstances and framework conditions. The term smart subsidy will be introduced in order to describe an appropriate subsidy, which reflects the above stated arguments, although no precise definition of the term exists in the current debate.

2.2.4 Smart subsidies

The central questions when designing a smart subsidy deal with the 'how', 'how much', 'to whom', 'under what rules', 'at what cost', and 'what is the exit strategy'? The answers to these questions lead to different strategies, each for particular circumstances. However, some important recommendations can be highlighted for smart subsidies:

- Support only those rural energy products and services that would not be viable without the subsidy, but for which there is verified sufficient demand. And encourage commercial participation.
- Follow rules that are clear, transparent and predictable to all parties and do not create or reinforce a monopoly or other market distortions.
- Focus on a clearly defined target group.
- Link subsidies to optimal results not technologies per se. Define targets which are neutral in terms of technology choice, but which support high quality and energy efficiency.
- Focus on increasing access by subsidising the initial purchase price rather than the operating costs or fuel consumption.
- Rely on existing and sustainable financial resources (budget, cross subsidies, foreign help, carbon finance) and have a clear exit strategy.

- Cover all aspects of the project including end-use investments, to encourage pro-poor income generating end uses.

As already mentioned above, nearly all these recommendations theoretically could be equally followed with direct or indirect subsidy approaches. In chapter three, cost efficiency and sustainability are therefore proposed as core criteria to assess the “smartness” of a subsidy.

2.2 Dissemination Models

In general two different approaches can be observed for the dissemination of improved stoves: commercial market oriented and non-commercial dissemination of low price stoves. These two approaches are not conflictive per se as they may both have their merits depending on their target areas and groups. Even following both approaches simultaneously is possible, as is successfully demonstrated by the EnDev Bolivia project (see chapter 3.3).

2.2.1 Non-commercial stove dissemination

Two major approaches can be distinguished for (the) non-commercial dissemination:

- to freely (or highly subsidised) give away mass produced stoves to poor households. This practice has been strongly criticised as unsustainable as these stoves tend to have a short lifespan and are unlikely to be replaced by the poor families.
- to train rural households to produce their own (typically mud-) stove from local materials. These self-produced stoves often have a shorter lifespan, but can be maintained by the user themselves. The efficiency is lower than of more sophisticated improved stoves, but efficiency also plays a lower role in rural areas than in urban and peri-urban areas where fuelwood has to be purchased for increasing prices.

Sometimes a mixed approach is chosen, when non-local materials (typically stove pipes and metal grates) are freely provided for the self-production of stoves.

2.2.2 Market building for disseminating stoves commercially

Market building approaches differ depending on their target groups and areas and the general market conditions and environment in the respective country. An important aspect in the different market building strategies is the issue of subsidies. As described in chapter 2.1 subsidies are inevitable if an endogenous market development cannot take place because of existing market barriers. While some approaches follow the rationale to only indirectly subsidise the market building to avoid market distortions, others claim that smartly designed direct subsidies with a clear exit strategy can significantly speed-up the market uptake.

The centrepiece of all commercial approaches is the stove producer, who has to claim ownership for its own stove business. All project activities should be designed to support, directly or indirectly, the successful market introduction of stoves by the producer, reducing his risk but not annulling it completely.

The integration of a decreasing product subsidy may follow two different rationales:

- to increase the impact of the marketing campaign by offering a price reduction to the customer for a limited time only. After this promotion campaign, prices are freely regulated by the market and may rise accordingly.
- to give the producers a clearly defined time frame for their “learning curve”, in which they can set-up their production infrastructure and reach economies of scale. Following this approach, the decreasing product subsidy is compensated by an increasing production efficiency over time.

3. Analysis of the country examples

In the following paragraphs the findings of the case studies in Bolivia, Burkina Faso, Ethiopia and Mali are compared regarding the experiences with different dissemination models and subsidy strategies. In a first step the dissemination model and different types of direct and indirect subsidies are analysed. In a second step cost-efficiency and sustainability are introduced and discussed as core criteria for the assessment of subsidy strategies.

Dissemination models

Of the four projects analysed most follow a pure market oriented approach. Only Bolivia tested two parallel intervention lines for the dissemination of mud stoves in rural areas. On the one hand the families have been trained directly by some local NGOs to self-construct their stoves (non-market-oriented dissemination); on the other hand local stove installers (local craftsman who offer several similar services) have been trained to build the stoves for the families (market-oriented dissemination). The training of local installers has proven to be more sustainable as the construction of mud stoves is – despite the simple and robust design – a sophisticated process which requires some experience/skill⁴.

Table 1: Improved stoves dissemination and subsidy models

Country Example	Dissemination Model	Direct Subsidies		Indirect Subsidies					
		1. Buy down grant	2. Start-up grant or soft loan	3. Custom or tax reduction	4. Awareness & promotion	5. Standards & certification	6. Support of micro-finance	7. Training & capacity building	8. Research & development
Bolivia	Market-oriented	X	X		X	X	X	X	X
	(Non) market-oriented ³	X		(X ²)	X	X		X	X
Burkina Faso	Market-oriented			(X ²)	X	X		X	X
Ethiopia	Market-oriented	X		(X ¹)	X			X	X
Mali	Market-oriented		X	(X ²)	X	X		X	X
Mali PEDASB	Market-oriented	X	?	(X ²)	X	?		X	?

1: Small businesses below an annual turnover of 33,000€ are generally excluded from the value added tax in Ethiopia

2: Stove producers/installers are part of the informal sector and do not pay VAT

3: Mud stoves have been disseminated in Bolivia both with a market and non-market oriented strategy

Indirect subsidies

All projects support to a certain degree research & development and capacity building for improved stoves. Awareness creation and promotion campaigns are equally part of the basic support strategies of stove projects. The development, introduction and institutionalisation of standards and certifications have been targeted by most projects, with the exception of Ethiopia where even the quality control has been entrusted to the market mechanisms. The evaluation as to how far the large number of producers (over 300) creates a sufficient market control compared to more regulative certification approaches of other projects would be interesting. Only in Bolivia microfinance institutions have been supported. This can be explained by the fact that beside the metal stoves in Bolivia most projects disseminate low

⁴ Two aspects have been highlighted in this regard: (1) the degree of compliance with the required geometry of the combustion chamber will determine the later efficiency of the stove, while (2) the quality of the clay-mud mix will strongly impact on the expected life time of the stove.

cost stoves only. The selling/installation price ranges between 3-5€, which can normally be paid upfront. The fact that most stoves are produced and installed by the informal sector complicates the involvement of microfinance mechanisms. Nevertheless, the experiences made in Bolivia should be further analysed in-depth for the future debate.

In table 2 the column (e) shows the share of indirect subsidies in the different country examples, which is generally above 80%.

Table 2: Cost and share of subsidies

Country Example	Dissemination Model	Stove type	(a) No of stoves (and SPM ¹)	(b) Dissemination cost per stove (resp. SPM)	(c) Stove price for the Customer	(d) Direct subsidies on stove price ²	(e) Project share of indirect costs
Bolivia	Market-oriented	Metal rocket type	5 825	€ 73 (€ 8) ⁶	€ 17/49 ⁵	€ 17/10 (50%-16%) ⁵	80%
	Non market-oriented	Mud rocket type	3 618 (160 000)		€ 4.40	€ 7.50 (63%)	
Burkina Faso	Market-oriented	Metal stove	22 723 (45 000)	€ 17.60 (€ 9)	€ 3.40	--	100%
Ethiopia	Market-oriented	Concrete Mirt stove	160 000 (370 000)	€ 25 (€ 11)	€ 3.40	€ 1.60 (24%)	97%
Mali FAMALI	Market-oriented	Metal stove	15 930 (40 000) ³	€ 25 (€ 10) ³	€ 2.30	€ 1.20 (26%)	95%
Mali PEDASB	Market-oriented	Metal stove	13 000 ⁴ (500 000) ⁷	€ 5.30 ⁴ (~€ 6.30) ⁷	€ 2.30	€ 1.20 (26%)	77%

1: For each country a sustainable production maximum (SPM) of disseminated stoves has been calculated, based on the number of trained producers, their monthly production rate, and lifespan of the stoves (including viability factors). Only Burkina Faso had already reached this maximum by October 2008, the potential cost efficiency of the project can be estimated based on the numbers given.

2: Respectively the stove price without subsidies

3: In contrast to Burkina Faso, in Mali the SPM will probably not be reached due to the PEDASB impacts on the Malian market development.

4: This number is not representative because it is based on a single NGO sub-contract and overhead costs of AMADER are missing.

5: Due to increased metal prices, the stove price almost doubled from US\$ 52 to 92 while subsidy has been reduced, thus almost tripling the consumer stove price.

6: Based on the assumption that mainly the mud stove is disseminated and direct material subsidies are soon reduced (see chapter 3.1).

7: Based on PEDASB's target of disseminating 500.000 stoves in 2005-2008 and the approx. budget of US\$ 5 Mio for the component.

Direct subsidies

In the case of improved stoves, which are typical entirely produced inside the target country, custom exoneration has no significance. The fact that informal and small producers and installers are explicit (Ethiopia) or de facto exonerated from value added tax reflects more the informal situation of many stove producers and does not represent a subsidy strategy. Regarding buy-down or start-up grants, only the project in Burkina Faso does not use direct subsidies. The Mali programme initially also did not offer any direct subsidies, but had to include some direct subsidy component because the World Bank is financing a stove programme in Mali which provides end product subsidies.

In Bolivia the initial strategy to disseminate a high quality and expensive metal stove to the peri-urban area failed due to a direct competition with (equally) subsidised LPG and the strong increasing metal prices. The activity is currently maintained on a low level to address some niche markets in areas without or with an unstable LPG supply, while the project focus shifted to cheaper mud stoves for remote rural areas. For the mud stoves the non-local materials (metal, stove, pipe and grate) are directly subsidised. Until now Bolivia spent about

20% of its project budget on direct subsidies.

In Ethiopia direct subsidies play the most important role as they are used on a broad scale (100 000 stoves) to speed up the market development. Subsidies are paid in cash to the producer via a coupon system. However, the share of direct subsidies in project costs only mounts up to about 3%.

In table 2 column (c) the sale price shows the real price for the customer including all subsidies. Column (d) presents the amount of direct subsidies and the percentage of the unsubsidised stove price. As far as possible, directly associated transaction costs of direct subsidies (e.g. the production and management of the coupons in Ethiopia) have been subtracted from the indirect project costs shown in column (e). However, many transaction costs such as the development, implementation and monitoring of the direct subsidies by the project staff are typically not documented in the projects and could therefore not be included into the analysis.

Cost efficiency of different subsidy strategies

The cost efficiency of a stove project (in terms of the average total project costs for the dissemination of one stove) might on one hand indicate a very efficient project and, or on the other hand very supportive framework conditions and should not be understood as a single indicator for project performance. The cost efficiency of a stove project is strongly influenced by the specific approach to reach multiplier effects (e.g. training stove producers). If the development of a local, producer driven market is successful, large numbers of stoves can be disseminated at low costs. Since market barriers differ in the countries, the project activities need to be adapted to the local requirements. Therefore some countries might be successful with an easier (and more cost efficient) approach that would not work in another country.

For comparison, project costs for stove dissemination have been calculated based on real sale numbers of stoves and the complete project budget (see Table 2 column a and b). In a second step a sustainable production maximum (SPM) has been estimated for each project that represents the maximum number of stoves that can be produced and replaced in the long run by a given number of producers. The SMS is calculated by the following equation:

$$\text{SPM} = N_{pr} \times V_{pr} \times P_m \times 12 \times L_{st} \times V_{st}$$

With N_{pr} := number of producer trained; V_{pr} := viability factor for producers, as not all trained producer remain in the business (assumed value: 0.8); P_m := average number of produced stoves per month and producer; L_{st} := average lifetime of the stoves and V_{st} := viability factor for stove lifetime (assumed value: 0.7).

Based on the theoretical production maximum, the potential cost efficiency of the project has been estimated (see table 2, column a and b, numbers in brackets).

It is interesting to note that, for example in Ethiopia, the share of direct subsidies on product price might be reasonable high (24%), still the impact of the direct subsidy component on project cost is very low. Or in reverse, there is no direct negative impact of direct subsidies on the cost efficiency of a project but cost efficiency and in general project success will depend mostly on the sustainability of the intervention, including direct subsidy schemes.

Sustainability of subsidy schemes

As the sustainability of project interventions and subsidy strategies can only be seen in the long run, the selected projects are difficult to assess in their current situation.

Only the *Malian project FAMALI* has already been completed and this only prematurely because of the interaction with the parallel ongoing PEDASB Program. Due to these special circumstances, FAMALI could not follow the originally planned approach and had to therefore adjust its activities with PEDASB. For the same reason, impact and sustainability of FAMALI are not directly assessable.

The *Burkina Faso stove project FAFASO* had at least completed its first phase in July 2007 and has since then focused on the rural areas and institutional stoves. The only specific

ongoing support for the urban stove producers are various radio and TV spots. The sales rate of the introduced stoves stabilised at around 2000 per month reaching 45 000 stoves in October 2008. This strongly indicates a viable market development and the success of FAFASOs market building strategy. Follow-up visits showed that the producer maintained their own quality control system and independently conducted small stove promotional activities. In the future it will be interesting to observe what kind of business strategy these informal producers choose: either maintaining their small scale, informal production or merging into larger and official producers.

The project in Bolivia works in a difficult environment for the dissemination of improved stoves. The urban and peri-urban areas, which in other regions quickly adopt improved stoves because of high woodfuel costs, are here mostly supplied with subsidised LPG. The first attempt to address this market with an improved stove failed. Hence the rural areas have been targeted with a mud stove model. The first attempt of training rural families directly via NGOs (which were partly already disseminating mud stoves) for the more efficient Malena stove type has shown to be only partly successful as stove construction demands a certain skill. Even though more than 7500 families have been, trained less than half as many Malena stoves have been ultimately built. Consequently a new strategy for the dissemination of the Malena stove has been introduced by qualifying about 400 rural craftsmen as certified stove installers, who build the stoves for the families, demanding an average daily wage for their service. It should be closely observed as to how this final strategy works in the long run and how the project is able to withdraw its direct material subsidy without disturbing market development.

The SUN-E project in Ethiopia follows a similar market oriented approach to the Burkina Faso project but tries to speed up market development with a direct subsidy for the first 100 000 stoves. Because the project on the one hand builds on many experiences and promotion activities of an earlier project, and on the other hand has only reached 50% of its direct subsidy target, the impact (quicker dissemination) or sustainability (further increase or decline of sales numbers after the subsidy withdrawal) of the direct subsidy strategy cannot be evaluated yet. The further development should be closely observed.

Conclusions and recommendations

In chapter 2 it has been shown that the debate on stove subsidies mainly focuses on direct subsidies. On the one hand there is no doubt that the dissemination of improved stoves needs public support, as this crucial technology which reduces indoor air pollution and the inefficient use of biomass in most areas, does not spread by itself, or if it does, only far too slowly. On the other hand, every public funded stove project represents at least an indirect subsidy for the introduction and promotion of stoves. Whilst indirect subsidies are generally accepted as inevitable, direct subsidies are however considered more problematic because there is the danger that they could in fact cause the very same market distortions that were the reason for their initial introduction.

At the same time it is argued that direct subsidies can speed up the market development when time is a critical aspect to consider. The praxis examples presented in this study are not sufficient to give a final answer to this debate. Still, some insight can be drawn which might help to advance the debate:

It seems that the significance of direct subsidies tends to be overestimated, while the potential market distortion effects of indirect subsidies are largely ignored. It could be shown that stove projects, even when following a strong direct subsidy strategy, still spend the largest extent of their budgets on indirect subsidies. But for indirect promotion activities the same question regarding cost effectiveness and sustainability can be raised as for direct ones. How sustainable is a national promotion campaign or certification system if activities cannot be maintained in the long run?

Thus, it is recommended to turn the debate on direct subsidies into a debate on smart subsidies regardless if these are direct or indirect ones. The term of 'smart subsidy' is just evolving and needs further definition and clarification. For the discussion of smart subsidies cost-efficiency and sustainability of interventions are proposed as core criteria as a structured and collaborative approach to advance the concept of smart subsidies would benefit the future stove dissemination most.

Because cost-efficiency of single intervention lines are currently not documented and analysis of sustainability includes the assessment of the local framework situation and projects impacts, it is not possible at the current stage to evaluate the “smartness” of the subsidies used by the several projects. Such an assessment should not be understood as a ‘specific’, ‘extra’, or ‘parallel’ assessment of a certain aspect of a stove project, but is closely interrelated with the general (impact) monitoring and evaluation. For a systematic approach, the issue of smart subsidies should be included into the established M&E system.

Impacts and sustainability of stove dissemination are currently on the top of the agenda of HERA/GTZ and the Energising Development partnership. Great efforts for impact monitoring and ex post evaluations are made to document experiences and advance strategies for a sustainable stove dissemination. At the same time Energising Development follows a strongly output oriented approach requiring every project to calculate its global project or subsidy costs per person.

Both monitoring approaches are currently undertaken on a 'global' scale, meaning that only the combined impacts and total costs of the projects are assessed. In contrast, most projects are not able to answer questions on the share of specific project interventions in the project's costs, manpower requirements, and impacts. For a more differentiated analysis on key interventions and subsidy strategies it would be of high interest to get a better grasp on “which interventions” have “what kind of impacts” in “which circumstances” at “what costs?”

It is apparent that this kind of monitoring cannot be completely accurate as it is often not possible to separate the impacts of several interdependent interventions. It is equally apparent that this type of monitoring should follow the same rational of impact and cost efficiency, and should be incorporated smoothly into the ongoing monitoring activities. But without trying to get at least an approximate idea of what impact I can expect and what it will cost if I follow a certain intervention strategy under certain circumstances, every project will start gathering its experiences from scratch, while the debate on smart subsidies remains as vague as it is today.

4. Country Example

The following chapter presents as case studies the 4 GTZ projects in Mali, Burkina Faso, Bolivia and Ethiopia. All projects disseminate improved stoves and have been co-financed by the Dutch-German Partnership Program Energising Development. The case studies are described in four steps:

- First: the projects and their key interventions are shortly introduced to provide a general understanding of the approach and strategy of each project.
- Second: on the base of M&E documents and short interviews the particular strengths and challenges are described together with the most important lessons learnt so far.
- Third: a info-box summarises all relevant information on stove technology, financing, subsidies and project sustainability. Unless specified otherwise, numbers are based on the last monitoring reports from end of June 2008. For currency calculation the exchange rates of 30.6.08 have been used as approximation.
- Fourth: a figure presents a quick overview of the most relevant interventions in terms of cash and direct subsidy flow, credits, training, marketing and quality control.

3.1 Bolivia - PROAGRO/EnDev Bolivia

The rural energy supply project EnDev Bolivia (project duration of 08/2005 to 12/2010) follows 4 different intervention lines of which only the stove component is subsequently discussed. The project aims to facilitate access to improved energy efficient stoves and solar stoves for households (HH) and social institutions (SI). The objectives are to reduce deforestation, improve the quality of life of users and achieve a sustainable market. To this end EnDev-Bolivia focus with three strategies on different market segments and customer preferences (see key interventions 3. and 4.)

The project target is to reach 229 500 people in schools and households, of which by June 2008 around 150 000 have been reached, with about 8 328 household stoves and 1 265 institutional stoves disseminated. Furthermore, the project tries to scale-up its impact by initiating a national stove campaign involving other actors to disseminate a total of 100 000 stoves until 2010.

Key interventions:

1. *Capacity Training* for manufacturing, business development and marketing for stove producers, including some financial support for prototype building, promotion and transport.
2. *Awareness rising* through information campaigns focussing on the different dissemination lines.
3. For (peri-)urban areas a relatively expensive (56-92 US\$⁵), but high quality and efficient semi-industrial *metal rocket stove* is disseminated. EnDev-Bolivia supports commercial stove producers, with a decreasing subsidy rate. The rate decreased from initially US\$ 26 to US\$ 15 in mid 2007 and has been complemented by mid 2008 with a loan scheme in cooperation with professional MFIs providing loans of around 40 US\$ for the purchase of improved stoves.
4. For rural areas, a different stove type is disseminated. The "*Malena*" *mud stove* with an enforced rocket burning chamber is the result of an extensive stove testing and development program at the Cochabamba University with GTZ. The stove is built on the spot mainly with local materials and is optimized for use of different fuels like wood, shrubs or cow and lama dung. EnDev Bolivia subsidizes non-local material (about US\$ 12 for chimneys, grates) and supports with supervision, awareness and social marketing. For the dissemination, EnDev-Bolivia has tested two different approaches, of which the latter is regarded as more successful:
 - Local NGOs have been supported to integrate Malena stoves in their portfolio and train local installers as well as families; the NGO received US\$ 26/10 in the first/second year for each stove constructed. 132 technicians and local promoters have been instructed, who trained about 7,500 households in the self construction of Malena stoves. The families use their own materials such as adobe bricks and mud.
 - 400 local stove installers have been trained in a certified 3 day course to offer their services to rural families for a construction fee, which is the equivalent of local man-day labour costs (about US\$ 4-10). GTZ supports with non-local materials such as chimneys and grates. The families have to provide local material such as adobe bricks and mud.
5. A *stove benchmark system* has been developed in order to certify stoves produced by the project and third parties. In cooperation with the Cochabamba University a stove testing centre (CPC) has been set-up to implement the certification.

⁵ Due to increasing metal prices the cost for an improved stove almost doubled from US\$ 52 in 2006 to US\$ 92 in 2008.

3.1.1.Strengths, challenges and lessons learnt

Strengths of the project have been:

- The same rules and regulations are being implemented for all producers. Although negotiations and contract signing has taken far more time than anticipated, this time investment “pays back”.
- The decreasing subsidy level shows a serious effort of making the market sustainable. It stimulates enterprises to think about lowering the production prices with anticipation.
- The selection of enterprises that produce a variety of different products, such as firewood stoves, solar stoves, dryers, toasters etc. A diversity of products on offer increases selling chances and makes promotion and transport more efficient.
- The offer of a second cheaper stove line, since target groups especially in rural areas are generally poor with little buying power. Also the fact that users or local installers know how to install and repair the stoves adds to the sustainability of this option.

Major challenges the project had to cope with:

- Because of the wide availability of subsidised LPG in urban areas, the metal rocket and the solar stove are not competitive (especially with the rising metal prices), but the project analysed a certain niche market potential for the better off population in rural areas, where LPG is not available.
- As in other countries, stove producers tend to concentrate on optimising their products in their “laboratories” rather than focusing on a good marketing strategy with clear selling arguments from the user perspective.
- The dissemination of large numbers and the set-up of a sustainable market within a short time period has been the major challenge and put a huge pressure on the appropriate exit strategy. As scarcity of firewood is not felt everywhere and the people who suffer from smoke (mainly women and children) are not the persons who decide over the HH budget (mainly men), the road to convince people to actually buy an improved stove is a long one, even though demand is said to be high.
- Difficulties to involve existing microfinance providers in stoves, as the financing of consumer goods is typically refused by MFIs and the transaction costs have been regarded as too high.

Main lessons learnt:

- Introduce different product lines reflecting the different product requirements and purchasing power of the target groups.
- Work towards improving the capacity of the contracted enterprises, especially marketing and sales skills, following a well thought out strategy. Training of current staff might not be the most effective option, since some specific personal characteristics are needed. Hiring an extra sales person who receives a fee for each stove sold might be an option.
- Identify a number of enterprises to work with in order to reduce the dependency of a single producer, which at a certain point might fall out.
- Adapt your exit strategy to your specific requirements: for the expensive metal stoves rising material prices hindered the complete subsidy withdrawal. With the offer of micro credits the project might be able to withdraw the direct subsidies in the long run without ruining the niche market. For the Malena stoves the replacement of the the metal chimney with a clay brick chimney is planned, reducing the non local materials to the metal grate, which could be locally purchased in the long run.

3.1.2. Infobox Bolivia

<u>Project information</u>	
Implementing Organisation	Energising Development Bolivia, PROAGRO GTZ,
Project partner	Ministry of Energy, several municipalities, World Bank, USAID, DED, cooperatives and NGOs
Dissemination model	Market oriented dissemination and non-commercial dissemination
Project period	08/2005 - 12/2010
Target area	6 of the 9 Regions of Bolivia (Potosi, Oruro, La Paz, Cochabamba, Santa Cruz and Beni)
Target group	Urban and rural poor
No. of stoves disseminated	By Oktober 2008: 9 593
<u>Technical System</u>	
Stove model	1: Solar stoves; 2: Rocket metal stove; 3: Rocket type clay stove (Malena)
Fuel	Wood (Rocket metal stove), wood and dung (Malena stove)
Components, materials	Solar stove: metal and wood; Rocket stove: metal and ceramic combustion chamber, Malena stove: clay, metal grate and stove pipe
Warranty, Quality	Solar and metal stoves: 1 year warranty (and approx. life time up to 5 years). Quality control and certification by a Bolivian stove testing centre (CPC) with clear benchmarks. Additional M&E. Life time of the Malena stove depends strongly from the used clay-mix and may well be beyond 5 years.
Specific design	Stove design of the Malena stove is very simple to be adopted even by families or informal local producers with low education
<u>Financing and subsidies</u>	
Total financing cost per stove (including all project costs)	Exchange rate (06/2008): 1€ = 1.55 US\$ (interbank exchange rate) Project budget 08/2005 – 06/2008: approx. 700 000€ Total budget until end 2010 not yet determined
End product price (incl. VAT)	Solar stove, rocket stove: US\$ 52-92, Malena stove: if self-constructed only local materials (mud, adobe bricks) and labour, US\$ 4-10 for a local stove installer. The wage of the local installer follows the local cost for a man-day of labour.
Credit scheme, interests and payback time	For the dissemination of the solar stoves and the metal rocket stove local microcredits are offered by 4 MFI. The MFI offer US\$ 40 loans with a max. 6 months payback time and the typical average 1.5-2% interest per month
Direct subsidy scheme	For the solar stoves and metal rocket stove subsidies of US\$ 26/15 have been paid for the first and second year respectively. The producer received some additional financing for project development, promotion and transport. The Malena stove has been supported with US\$ 12 for non-local materials (grate, stove pipe)
Direct subsidy amount (total/%)	Metal rocket stove: as stove cost increased, subsidy has been reduced from US\$26/50% in 2006 to US\$ 15/15% in 2008. Malena Stove: US\$ 12/65% in form of the metal materials
Indirect Subsidies	Training (skill, quality, organisation, commercialisation), marketing and awareness campaigns
<u>Market environment</u>	
Actors, product maturity, producer, customer, demand	For the metal stoves, the project works with 1 active producer (of 4 that have been trained). For the Malena stoves about 7500 families and 400 local installers have been trained in stove construction.
Activities of other actors	There are no other actors which support the dissemination of metal stoves, but several NGO activities for the dissemination of Lorena adobe stoves in rural areas. EnDev Bolivia tries to include these NGOs in their Malena stove campaign, as the Malena stove has a higher efficiency
Market volume	The existing market for unsubsidised metal stoves consists of wealthier rural families, who normally use LPG and buy the rocket stove as a backup for LPG shortages. In the remote rural areas outside the LPG distribution system a huge market for the Malena stove exists.
<u>Project sustainability</u>	
User level: Capacity for operation and maintenance	Metal stoves are of high quality with an expected lifespan of 2-5 years. Corrosion might be a problem if the stove is not protected from humidity. For the Malena stoves local capacity for maintenance is secured by extensive training of families and installers, but quality depends heavily on the clay-mix used for the stove construction.
Producer level:	400 producers have been trained, which is sufficient for increasing the production while replacing old stoves.
Programme-/ Project level: market distortions	For metal stoves, the project gradually converted the direct product subsidy into a microcredit system. The Malena stove dissemination depends on the ongoing support of non-local materials, as long as the local production capacity for metal parts does not exist.
Exit strategy	By mid 2008 the project had ended the direct subsidies for metal stoves, the supply of metal parts for the Malena stoves continues until the project termination in 2010
Risk	Increasing metal prices, non profitability for the microcredit system, long-term access to metal components (at least the grates) for the Malena stove in remote rural areas.
Scaling Up Potential	Larger potential is tackled by the project initiating a national stove campaign to reach 100 000 stoves by 2010

3.1.3. Subsidy scheme Bolivia

Average cash flow and indirect subsidies for the dissemination of one improved stove

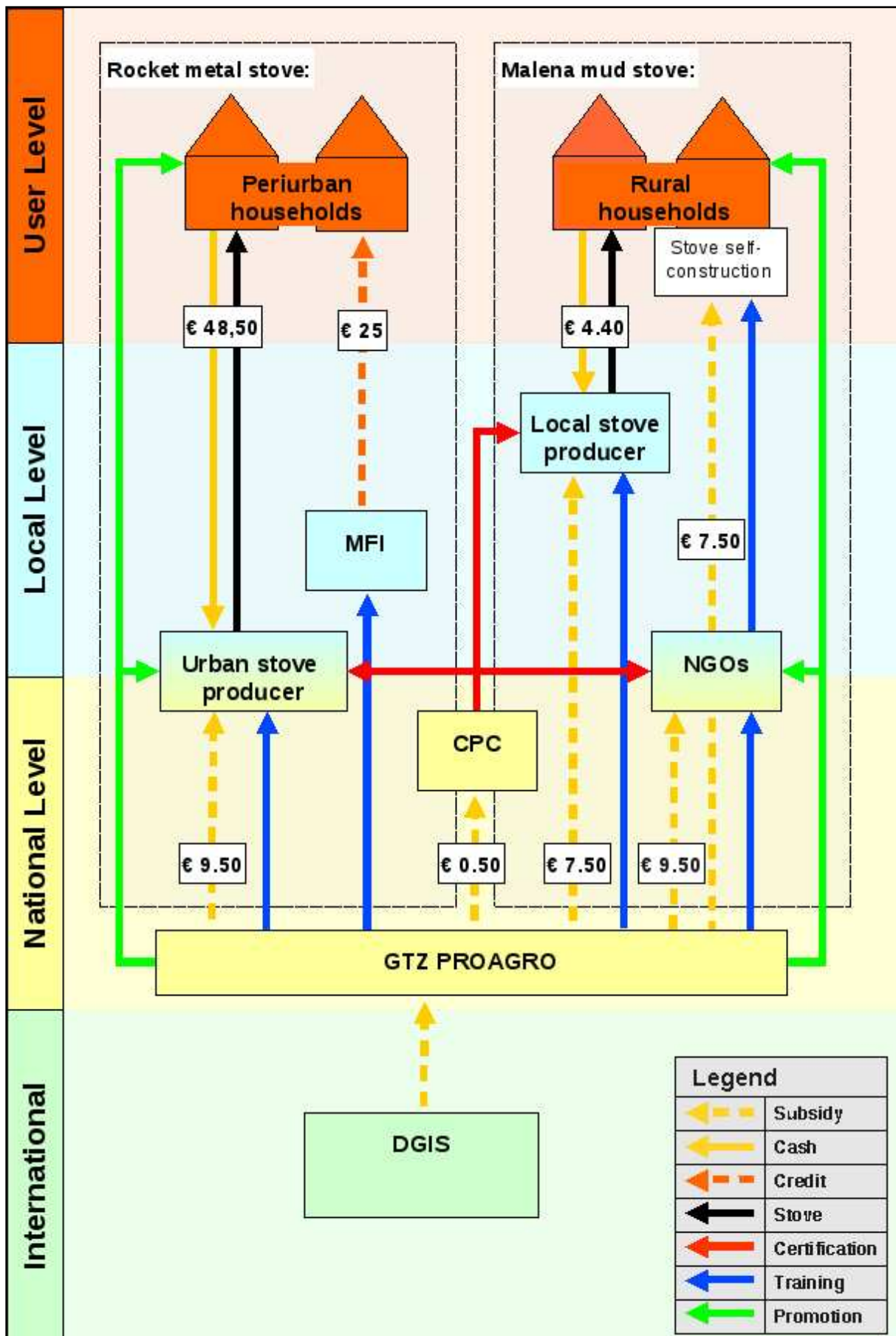

3.2 Burkina Faso - Foyers Améliorés au Burkina Faso (FAFASO)

FAFASO aimed during its first phase from 07/2005 to 06/2007 for the commercial dissemination of improved household stoves in Burkina Faso's two major cities, Ouagadougou and Bobo Dioulasso. In addition, some tests on implementing improved institutional stoves were undertaken. The objective set at the beginning of the project was to reach 90 000 people in Burkina Faso, i.e., considering the average household unit with 6 persons, the dissemination of 15 000 stoves. The project was jointly implemented with a similar project in Mali (FAMALI see page 28).

Key interventions:

- *Increasing production capacity* by training for new and existing stove producers on technical skills as well as on promotional and marketing strategies, business management and quality control mechanisms.
- *Awareness raising* by training of advisers in NGOs and information services in kitchen and fuel management. In addition promotional activities through the use of mass media such as television, radio and newspapers, exhibitions, local markets, etc. shall be supported to achieve widespread awareness and demand for this technology.
- *Training in marketing skills* directed to productive users like restaurants, agricultural processing, schools, prisons and health centres.
- *Training for production* of 2nd generation of improved stoves by training of all entrepreneurs in additional skills to produce and sell new and more efficient technologies (like the rocket stove) which have been introduced in other countries.

3.2.1. Strengths, challenges and lessons learnt

Strengths of the project have been:

- No "distribution", but "dissemination", no direct subsidies on the sale's price, only market building
- Strong marketing campaign, already known even in other towns due to TV spots, easier up-scaling
- Flexibility of the outcome oriented funding approach of EnDev, project could quickly adapt to local requirements

Major challenges the project had to cope with:

- *The "project mentality"*: The fact that Burkina Faso has seen a multitude of improved stove projects since the 1970s showed up as one of the major problems of FAFASO. All actors involved in improved stoves' "business" have adopted, by long trained attitudes, a "project mentality". This means that subsidies are taken for granted, that own initiative does rarely appear and that, lastly, failure is not considered to be a catastrophe but rather a normality.
- *Creating equivalence between offer and demand*: The second major problem was to create good equivalence between the offer and the demand for improved stoves. Training and marketing activities have to be closely coordinated to provide the offer when the awareness is greatest.
- *The changes in the producers' mentality*: Up to today, only few of FAFASO's producers have really adopted the logic to produce for an abstract market (i.e. to produce on stock): most of them prefer still to produce only if a concrete order is there. This causes problems running commercial shops installed by the project at the end of the 1st phase. Many producers are not willing to deliver their stoves to a shop, to only receive payment once the stoves have been sold. In general, project activities were much more fruitful in Bobo Dioulasso, where producers were not

used to subsidies and assumed their own responsibility more intensely.

- *Execution of the marketing campaign:* A more practical problem lay in the execution of the marketing campaign. While the process of the development of the visual identity, the logo and the spots was a very positive and fruitful experience, the execution of the campaign itself faced lots of practical problems such as irregularities and low quality of promotion activities. These problems pushed the project to organize the 2nd part of the marketing campaign itself – with an assistant especially hired to control the correct execution of the different secured contracts.

Main lessons learnt:

- Listen to “stove” experts, but do not follow automatically their advice (there has to be some reason why so many stove projects have failed). Integrate experts in other disciplines (e.g. marketing) and young persons with fresh ideas into your team.
- Put aside all organisations that have for a long time taken profits from stove projects without showing own engagement.
- The producers are key persons: they have to adhere to the project's objectives and they have to understand their own responsibility for (their own) success. Do not act for the producers, but always with them. Instead, stand aside and give them independence. Otherwise they will always think that they act for you and not for themselves.
- Hire experts for key activities, but always have a careful control on their activities (e.g. PR-agencies).
- Make the product known, not the project!!!
- Give a unique visual identity to your product (stove).
- Explain the necessity of the product in a language that people will understand (environment is rarely a good argument in third world countries; economy is a much better one).
- Try to reach the clientele who have the power of decision (= the money) do not automatically address your message only to the women who often cannot decide on the purchase of a stove.

3.2.2. Infobox Burkina Faso

<u>Project information</u>	
Implementing Organisation	German Mission for the Support of CILSS -Dissemination of improved stoves (FAFASO -Foyers Améliorés au Burkina Faso), 02.2028.005-02
Project partner	Ministère de l'Environnement et de Cadre de Vie, Ministère de l'Energie, des Mines et des Carrières, Institut de Recherche en Sciences Appliquées et Technologies (IRSAT)
Dissemination model	Market oriented approach
Project period	07/2005 - 06/2007
Target area	The towns of Ouagadougou and Bobo Dioulasso
Target group	Rural and urban poor
No. of stoves disseminated	22 723 (June 2007), 45 000 (October 2008)
<u>Technical System</u>	
Stove model	Roumde Stoves, a locally developed and easy to manufacture stove design
Fuel	Typically wood, the Mixte, Multimarmite and Tulipe have additional charcoal grates
Components, materials	3 metallic types (Burkina Mixte, Multimarmite – for different pot sizes, Ouaga Métallique) and a clay model (Tulipe), for institutional use a large size adobe model has been developed
Warranty, Quality	Monthly quality checks by quality control commissions of the producers' associations (material, manufacture, geometry of the combustion chamber), additionally every 3 months IRSAT does control visits, which are paid by GTZ (cost coverage by the producers themselves would increase the stove price for about 150 CFAF). The expected lifespan is about 2 years
Specific design	Stove design is very simple to be adopted even by informal producers with low education
<u>Financing and subsidies</u>	
	Exchange rate (10/2008): 1€ = 656 CFA France (fixed rate to the Euro)
Total financing cost per stove (including all project costs)	By June 2007 about 17,60 Euro had been spent for each stove disseminated, by October 2008 total sales of 45 000 stoves could be reached reducing the cost to 8,90 Euro per stove.
End product price (incl. VAT)	2.30 – 4.60 Euro (1500-3000 CFAF) depending on model and size. Prices are agreed by the producer associations, resellers receive discounts, most of the producers are from the informal sector and do not pay VAT. Prices in rural areas are sometimes higher, because of the higher material costs.
Credit scheme, interests and payback time	No credit involved
Direct subsidy scheme	No direct subsidies
Direct subsidy amount (total/%)	--
Indirect Subsidies	Training (skill, quality, organisation, commercialisation, new devices), marketing campaign and the quality control by IRSAT have been financed
<u>Market environment</u>	
Actors, product maturity, producer, customer, demand	From earlier interventions during the 80s some professional stoves for breweries remain, but little in the household sector. The project trained about 100 producers in the two towns
Activities of other actors	There are no other actors who support the dissemination of metal stoves, but several NGO activities for the dissemination of adobe stoves in rural areas
Market volume	Beside baseline studies in three towns, no studies on national market potential have been conducted.
<u>Project sustainability</u>	
User level: Capacity for operation and maintenance	Metal stove maintenance need some introduction to avoid accelerated corrosion of the metal grates. The repair of adobe stove requires some pottery skills.
Producer level:	150 producers have been trained, which is sufficient for increasing production and replacement of old stoves.
Programme-/ Project level: market distortions	Market oriented approach, no distortions expected
Exit strategy	The project focus has been market building, with no direct subsidies. The only problem of the project withdrawal is the financing of the quality control by the producer associations themselves. This would require an increase in the stove price of about 0.5€.
Risk	Increasing metal prices, no independent/effective quality control (loss of quality and trust of the stove label), introduction of end-price subsidised stove programmes by other donors.
Scaling Up Potential	Because of the long history of stove dissemination in Burkina Faso a general awareness does exist. The radio and TV spots of the marketing campaign focussed this awareness on the introduced stove label even in rural areas and small towns, which offers a favourable condition for the current extension of the project area.

3.2.3. Subsidy scheme FAFASO

Average cash flow and indirect subsidies for the dissemination of one improved stove

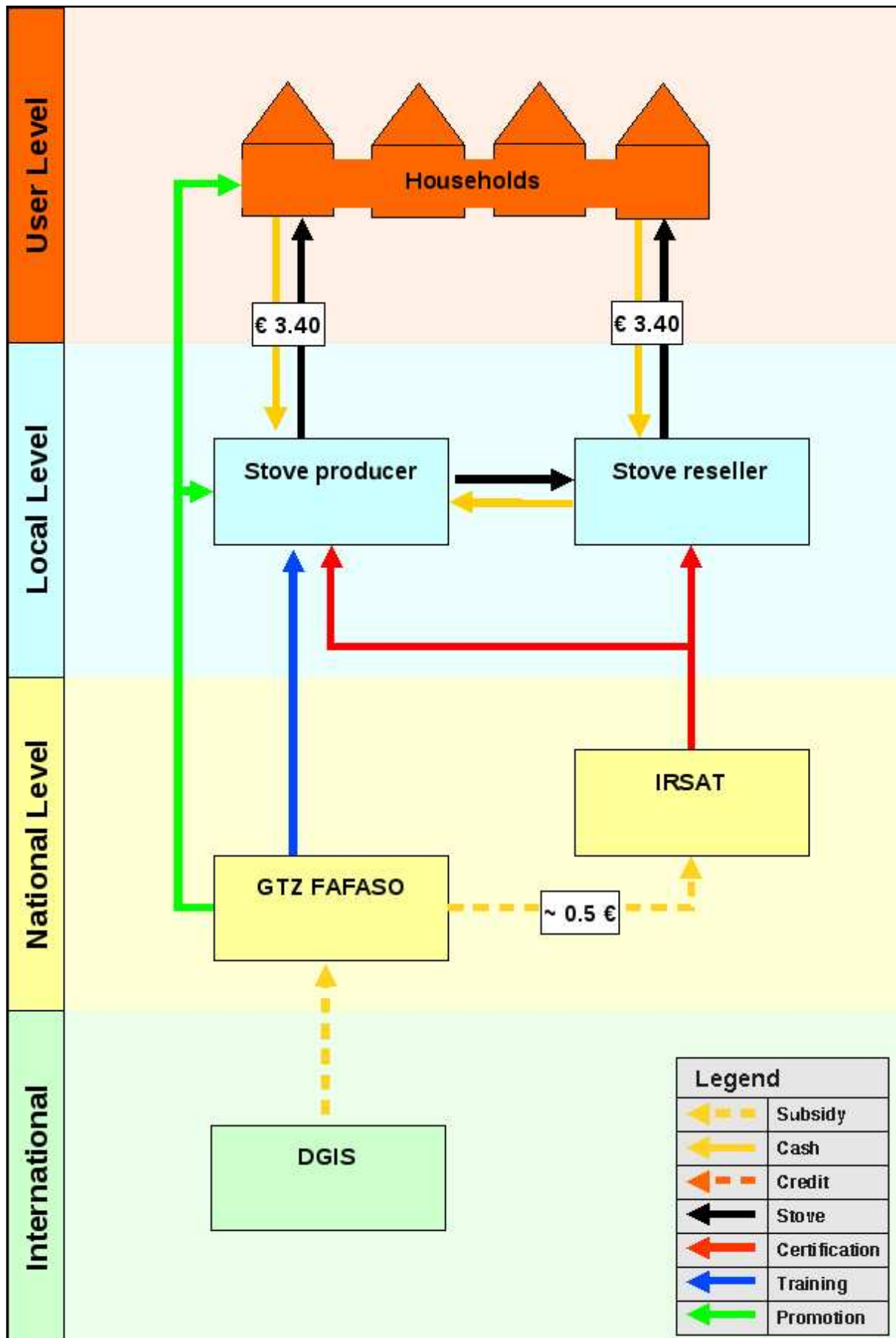

3.3 Ethiopia - SUN-E/EnDev Ethiopia

The GTZ Sustainable Utilization of Natural Resources for Improved Food Security Program Energy (SUN-E) is the continuation of the former Household Energy Protection of Natural Resources (HEPNR) project and is jointly implemented by GTZ and the Ethiopian Federal Ministry of Agriculture and Rural Development (MoARD). The program component started in 10/2005 with the aim to disseminate 250 000 improved stoves in rural towns and semi-urban regions until 04/2009. In the beginning the project focussed on a massive Mirt stove model. After a sharp increase of cement prices a slimmer Mirt stove has been introduced and two alternative stove types (Tikikil – a one pot portable cooking stove and Gonziye – a clay stove for rural areas) are in development. The project used a direct subsidy approach of the former HEPNR project for initiating the market combined with a clear exit strategy.

Key interventions:

1. *Awareness raising:* Several promotion activities have been carried out including the dissemination of leaflets, posters, billboards; newspaper (later cancelled because they did not reach the target groups as demonstrated by the results of the impact study), radio and TV advertisements and organisation of public cooking demonstrations. SUN-E and the producers participated in trade fairs or exhibitions.
2. *Training and Marketing:* training of trainers, assistance for business start-up and marketing support; establishment of a micro enterprise network; retraining for production of the improved slim Mirt; additional business management training for selected stove producers to enhance their marketing skills.
3. *Direct subsidies:* support of fast market penetration by producer subsidies (of 20 ETB ~ €1.60 on stove price) for the first 100 000 stoves in cooperation with credit and saving institutions in Amhara and Oromia.
4. *Enhancement of biomass fuels supply:* support for firewood planting and marketing by different parts of the community and private sector.

3.3.1. Strengths, challenges and lessons learnt

Strengths of the project have been:

- In all three regions a team is in place with qualified professionals.
- A network of relevant qualified institutions and individuals is in place, informed and common knowledge and objectives understood and supported. The network functions from central to regional, Woreda and Kebele level. Typical institutions in the network are for example the Bureau of Agriculture and Rural Development, Bureau of Mines and Energy, the Dept. of Women's Affairs, microfinance institutions, the office for SME development and the Ethiopian Rural Energy Development and Promotion Centre (EREDPC). Awareness of objectives throughout the structure is evident.
- In some cases the inclusion of the household energy component in the SUN programme's watershed activities has been successfully implemented with the use of a revolving fund that facilitated, interest free, instalment payments for the purchase of improved stoves and establishing producers within the watersheds.
- Major challenges the project had to cope with:
 - *Prices for Cement* (the main material for the Mirt stove) increased from 1998 to 2008 by about 220% (from 33.4 to 120.9 ETB per 50 kg), with its sharpest increase in 2002/2003 (20.6%). To reduce stove price a "slim" Mirt stove design has been developed.
 - *Coupon system failure:* The remarkable boost in stove sales in Tigray during the years 2005 and 2006 is attributable to the coupon-based subsidy system. The sudden drop of sales figure in the subsequent years following the escalation in prices of raw material and later the temporary discontinuation of the coupon

system indicates that the coupon-based subsidy has not actually helped the real market to grow and expand in a self-sustaining manner. For the second coupon phase, the strategy emphasises a clear and pre-announced exit strategy and the market development will be closely monitored.

Main lessons learnt:

- *Problems with monitoring:* The monitoring system was initially not appropriate to determine the exact sales figures and the degree of stoves in use by the households. In 2008 a survey assessed the reliability of statistical data/sales figures from the producers and covered information about the sustainability such as correct usage, replacement and also the maintenance of stoves by users.
- *Requirement of direct start-up subsidies:* Despite similar trends in the price of raw materials, Mirt business in Amhara and Oromia regions was doing well without any form of subsidy. The project has learnt lessons from Tigray that consumers' subsidy distorts the real market prices. Similar subsidy was initiated in late 2007 in Amhara and Oromia. In order to mitigate the adverse impacts of consumer subsidy on actual market prices, consumers in these two regions were being told that the subsidy will only be there for a short period of time (until 50 000 stoves in each region have been sold). The impact of the subsidy system will be closely observed.
- *Integration into other rural Areas' Interventions:* for the penetration of rural areas, it might be worthwhile to integrate cooking energy issues into the overall SUN/SLM Water Shed interventions and develop pilots and lessons learnt for further distribution of energy saving cook stoves in rural areas.
- *Address as well (peri-)urban areas:* The success in (peri-)urban areas could be increased reaching economies of scale by using the Tikikil stove to scale up activities in Addis Ababa since the market and production capability is available.

3.3.2. Infobox Ethiopia

<u>Project information</u>	
Implementing Organisation	GTZ Sustainable Utilization of Natural Resources for Improved Food Security Program Energy (Sun-E), former Household Energy Protection of Natural Resources (HEPNR) project
Project partner	Mines and Energy (MoME) and Min. of Agriculture and Rural Development (MoARD)
Dissemination model	Market oriented approach
Project period	08/2005 - 04/2009 (Sun-E), 1998 - 2006 (HEPNR)
Target area	The regions Tigray, SNNPR, Amhara & Oromiya (HEPNR) and Amhara & Oromiya (Sun-E)
Target group	Urban and rural poor
No. of stoves disseminated	By June 2008 in all 4 regions: 120 000 (since 2006), 205 000 (since 1999); disseminated using direct subsidies (coupon systems): 43 500 (October 2008), target 160 000 stoves.
<u>Technical System</u>	
Stove model	1.Mirt stove; 2.Tikikil stove (a one pot portable stove); 3.Gonziye stove (a clay stove for rural areas)
Fuel	Mirt and Gonziye stove: wood, dung ; Tikikil stove: wood and charcoal
Components, materials	1.Mirt stove: mortar; 2.Tikikil stove: metal, mortar; 3.Gonziye stove: clay
Warranty, Quality	No label or quality system but pure market mechanism. 1.Mirt stove: lifetime of 5 years; 2.Tikikil stove: lifespan of 2 years or more expected; 3.Gonziye stove: lifespan yet to be determined
Specific design	Proper advice from the stove sellers for the small fuel inlet of the Mirt stove required. Some specific users (who use firewood from difficult to chop tree species) still prefer a wider fuel inlet
<u>Financing and subsidies</u>	
Total financing cost per stove (including all project costs)	Exchange rate (06/2008): 1€ = 15 ETB (interbank exchange rate) Project budget: 4 Mio € Sun-E, resulting in about 160 000 stoves with 25 € costs per stove
End product price (no VAT incl. As small enterprises are excl. from VAT)	1.Mirt stove: 60-90 ETB; 2.Tikikil stove: ~150ETB; 3.Gonziye stove: 30-40 ETB Prices develop freely on the market.
Credit scheme	No credits involved
Direct subsidy scheme	A coupon system, which was developed by the HEPNR project in the Tigray region, has been applied since November 2007 for the first 50 000 stoves in the Amhara and Oromiya regions respectively. Based on the local raw material prices the sales price and direct subsidy rate have been fixed.
Direct subsidy amount (total/%)	20 ETB (1.34 €) per stove, 27% of the average market price
Indirect Subsidies	Training (skill, quality, organisation, commercialisation), marketing and awareness campaign
<u>Market environment</u>	
Actors, product maturity, producer, customer, demand	Other NGO's and development agencies occasionally incorporate the stove business into their development agenda.
Activities of other actors	Government agencies (mainly regional energy, agriculture, offices etc) also have interest in the stove sector. But their activities are limited to some specific areas within their localities and on technical training and backstopping.
Market volume	Market studies in 1998 identified a huge potential for the large scale dissemination of fuel saving technologies especially for household use (inefficient utilization of fuels, dwindling supply side, households already switching to multiple fuel and stove use or other saving strategies.
<u>Project sustainability</u>	
User level: Capacity for operation and maintenance	Maintenance is not a problem for Mirt. A damaged part could easily be replaced by the user. The assembly of the parts into stove is carried out using mud mixed with straw which is easy to prepare and use. With no parts made of metal, corrosion is not an issue.
Producer level:	In the 4 regions in total 370 producers have been trained in 230 towns of which 306 have been in business since March 2008. In the SNNPR Region 21 producers established their business with support of HEPNR until 2005. The fact that until 2008 they ran their business independently (beside some indirect profit from national promotion) indicates sustainability of market building.
Programme-/ Project level: market distortions	Potential market torsion of the coupon system still needs to be evaluated. Good experiences exist with an improved charcoal stove (<i>Lakech</i>) introduced some 20 years back. The stove is still on market with independently operating private stove sellers.
Exit strategy	Clear exit strategy as only the first 100 000 stoves receive a 20 ETB per stove price subsidy for market stimulation.
Risk	Increasing material prices, no market uptake after subsidy withdrawal
Scaling Up Potential	There is potential to cover more regions or to introduce new stove types (like the Tikikil) to also address urban areas like Addis Ababa.

3.3.3. Subsidy scheme Ethiopia

Average cash flow and indirect subsidies for the dissemination of one improved stove

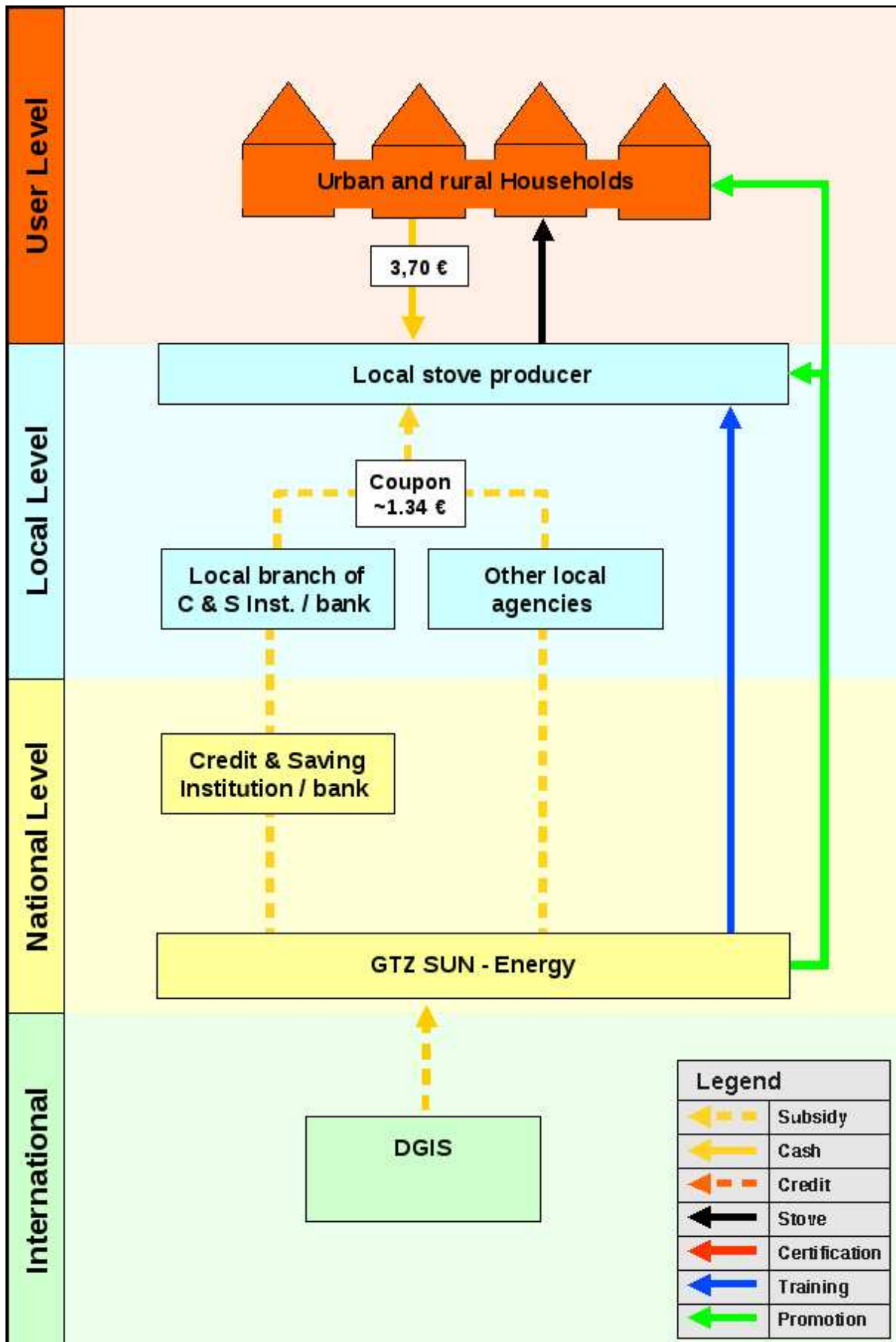

3.4 Mali - Foyers Améliorés au Mali (FAMALI)

FAMALI aimed during its first phase from 09/2005 to 06/2007 at the dissemination of improved household stoves in Mali's three major cities, Bamako, Ségou and Sikasso. In addition, the set-up of an industrialised production of the SEWA Stove should be facilitated. The objective set at the beginning of the project was to reach 90 000 people in Mali, i.e., considering the average household unit with 6 persons, the dissemination of 15 000 stoves. The project was jointly implemented with a similar project in Burkina Faso (FAFASO see page 21).

Key interventions:

1. *Increasing production capacity:* Training for new and existing stove producers on technical skills as well as on promotional and marketing strategies, business management and quality control mechanisms.
2. *Awareness raising:* Training of advisers in NGO's and information services in kitchen and fuel management. In addition promotional activities through the use of mass media such as television, radio and newspapers, exhibitions, local markets, etc. shall be supported to achieve widespread awareness and demand for this technology.
3. *Training for production of 2nd generation of improved stoves:* Training of all entrepreneurs in additional technical skills to produce and sell new and more efficient technologies (like the rocket stove and the metal stove with an efficiency improved by 70%), which have been introduced in other countries. Training in marketing skills directed to productive users like restaurants, agricultural processing, schools, prisons and health centres.

3.4.1. Strengths, challenges and lessons learnt

Strengths of the project have been:

- The small team was quickly extended with a professional marketing expert for the marketing campaign and 3 community animators to monitor the activities of the project in the 3 target cities.
- Setting-up of a raw material supply scheme with the local craftsmen association (APCMM).
- Introduction of a quality control and label system with the National Centre for Solar and Renewable Energies (CNESOLER).

Major challenges the project had to cope with:

- The firstly foreseen institutional partner of the project, PREDAS, was planning "old style" improved stoves projects. Instead of focusing on market building activities at the producer side, the PREDAS focused on the subsidised dissemination of stoves via non-commercial actors (NGO, women organisations). At the end it was decided to separate from PREDAS and to create a National Cell for the execution of the project in Mali.
- Unfortunately the existence of AMADER and its project PEDASB was hidden from the GTZ until February 2006. PEDASB is supported by the World Bank and has an objective of 500 000 Improved Stoves sold until 2009. AMADER plans a stepwise reduction of subsidies from 50%/25%/0% in the first/second/third year respectively. Unfortunately, PEDASB expands its activities every year for more producers bringing the third year producers who sell the first time without subsidies in direct competition with first year producer who receive 50% subsidy.
- Even if a Letter of Understanding had been signed between GTZ and AMADER, the FAMALI project was seen by the AMADER team as a competitor while the bureaucracy is very heavy in Mali, and a little decision takes a lot of time to be

taken.

- There have been many stove projects in Mali and producers are very used to projects which give a lot of things to the producers without compensation or participation of producers. They have a precise idea of development project mechanisms and always attempt to “bargain” their work.
- When the project started, raw material supply for metallic stoves was problematic, even for producers working with AMADER. The project had then developed a supply scheme with the Craftsman Chambers Union (APCMM) and local Craftsman Chambers in the 3 cities of the project.

Main lessons learnt:

- Demand for institutional analysis during the planning phase which should not be led by a GTZ partner, but by GTZ itself or an independent consultant. Then, Letters of Understanding should be signed with the most important institutional stakeholders.
- To emphasise marketing aspects for stove dissemination, recruit a marketing expert within the project who controls the work of contracted agencies on a day to day basis.
- The project decided to develop a supply scheme with a perennial structure which can assure the management of the fund after the project. This type of partnership is successful, because of the interest of such a structure to show its beneficiaries (craftsman) that it is working for them. The sustainability of the system is then ensured by this interest and the durability of the structure.
- By the end of the project the reimbursement rate of the APCMM credit scheme was about 79%, which can be regarded as success. Moreover, in a last meeting with APCMM and the producers, they all recognized the success of the fund and producers made a commitment to reimburse all their debts. On the other hand GTZ had a problem withdrawing from fund management, as the APCMM stressed that it would be easier for them to keep some pressure on craftsman, because the GTZ Cooperation project has always been seen as the leader. APCMM is now managing a 7 600 € revolving fund and is supported by producers, who will be involved in the fund management,
- AMADER is supposed to continue the activities linked with the quality label: AMADER will cover the costs of the quality control, which will be done by CNESOLER, and label stickers distribution will be in charge of the AMADER Regional Coordination, AMADER will find solutions to insert new producers in the subsidy system on a case by case basis, AMADER will continue the marketing campaign on the Quality Label (provisional budget of 15 000 €).

3.4.2. Infobox FAMALI

Project information	
Implementing Organisation	German Mission for the Support of CILSS, Dissemination of improved stoves FAMALI - Foyers Améliorés au Mali, 2002.2028.5-002.00
Project partner	PREDAS (Regional Program for Household Energy Promotion in Sahel Countries)/AMADER (Malian Energy Agency), implementing the WB funded PEDASB project 2005-2009))
Dissemination model	Market oriented approach
Project period	09/2005-06/2007
Target area	The towns of Bamako, Ségou and Sikasso
Target group	Urban poor
No. of stoves disseminated	15 930
Technical System	
Stove model	3 locally developed simple stove designs: 1. Teliman; 2. Nafacaman and 3. Sewa
Fuel	Teliman: wood; Nafacama: charcoal and wood; Sewa: charcoal
Components, materials	Teliman and Nafacama: metal; Sewa: metal and ceramic
Warranty	No warranty on stoves, but quality label and external control of material, manufacture and geometry of the combustion chamber
Specific design	Teliman: simple cylindrical design; Nafacama: rhombical metal form; Sewa: metal with ceramic combustion chamber
Financing and subsidies	
	Exchange rate (10/2008): 1€ = 656 CFA France (fixed rate to the Euro)
Total financing cost per stove (including all project costs)	25 Euro per Stove, not including future stove sales. (on the longer term, assuming 70% of the trained producer sell 30 stoves a month, a number of 40 000 stoves could be reached reducing the cost to 10 Euro per stove)
End product price (incl. VAT)	2.30-4.60 Euro (1500-3000 CFAF) depending on model and size. Prices are agreed by the producer associations, resellers receive discounts, most of the producers are from the informal sector and do not pay VAT. Prices in rural areas are higher, because of the higher material costs.
Credit scheme, interests and payback time	The local craftsmen association (APCMM) provides the producer with material on a credit base.
Direct subsidy scheme	The project initiated the APCMM material supply system with the supply of free material for about 8400 stoves (approx. 19 000 €). The producer can buy the material at a reduced price on a credit base. No further direct subsidies are involved.
Direct subsidy amount (total/%)	Discounted on the 15 930 Stoves the average direct subsidy has been 1.20 € or 35% of the average stove price.
Indirect Subsidies	Training (skill, quality, organisation, commercialisation, new devices), marketing campaign and the quality control by CNESOLER (now financed by PEDASB)
Market environment	
Actors, product maturity, producer, customer, demand	Improved stoves have been introduced in Mali for long time, but no independent market has been developed so far.
Activities of other actors	AMADER implements the World Bank funded PEDASB project (2005-2009) with the target of 500 000 Improved Stoves sold until 2009. The PEDASB approach is to subsidize stoves at a rate of 50%/25%/0% in the first/second/third year respectively
Market volume	The large demand for improved stoves exceeds the existing supply in urban areas, while rural areas have still little access
Project sustainability	
User level: Capacity for operation and maintenance	Metal stove maintenance need some introduction to avoid accelerated corrosion of the metal grates.
Producer level:	100 producers have been trained, which is sufficient for increasing production and replacement of old stoves.
Programme-/ Project level: market distortions	No market price sale of stoves as long as PEDASB gives subsidies, but stepwise reduction is planned.
Exit strategy	Only start up subsidy for APCMM; in the case of PEDASB, AMADER plans stopping direct subsidies by the end of the third year, difficulties arise from the fact that AMADER has first and third year project close-by which compete in sales
Risk	Increasing metal prices, loss of product quality and trust in the product label if PEDASB does not take over the FAMALI approach of an external quality control
Scaling Up Potential	PEDASB receives funds from the World Bank to expand its activities.

3.4.3. Subsidy scheme FAMALI

Average cash flow and indirect subsidies for the dissemination of one improved stove

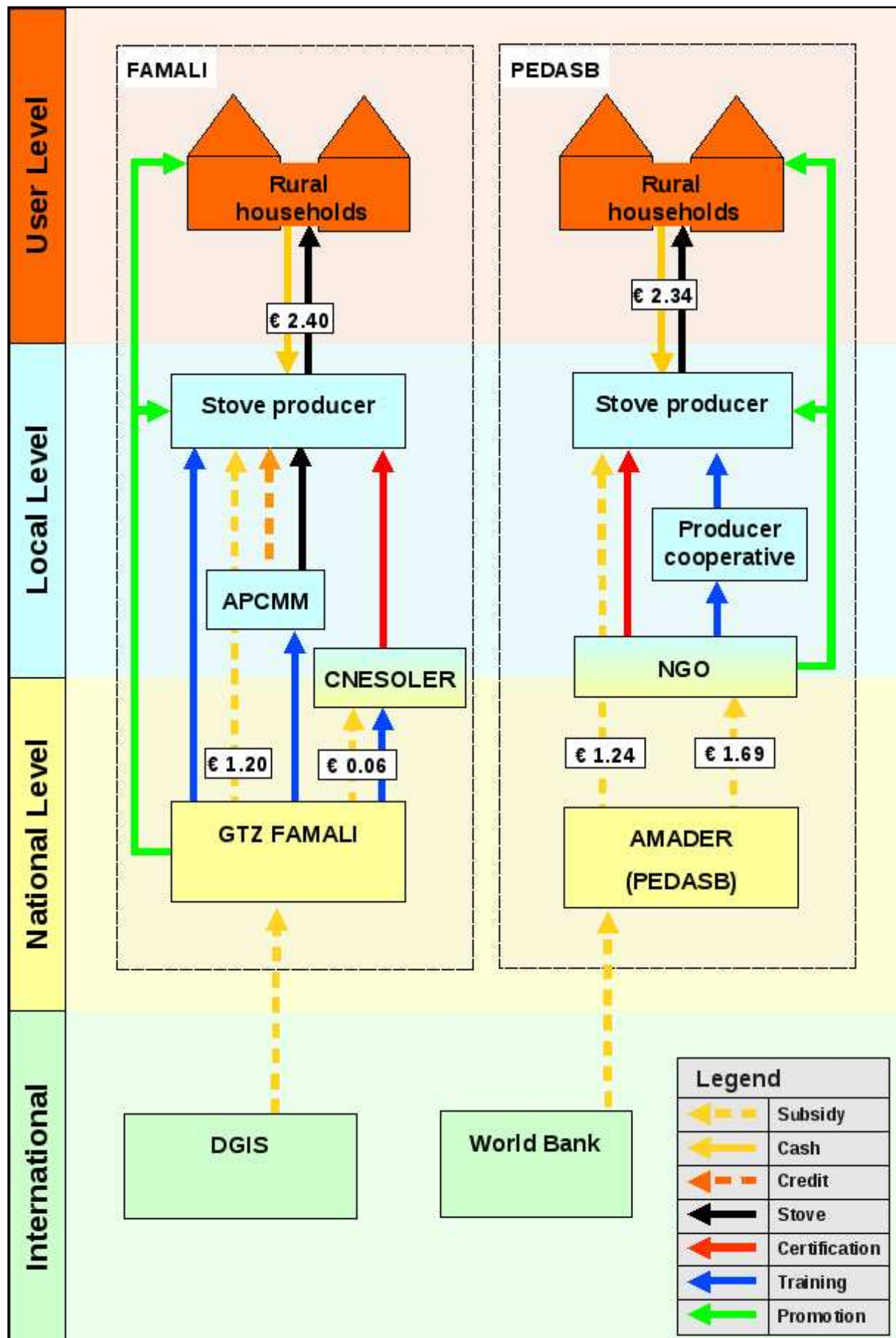

5. Literature

Barnet, A. Voluntary Codes of "Best Practice" for Donors and NGOs for Renewable Energy & Developing Countries <http://www.hedon.info/goto.php/CodeOfBestPracticeForRenewables>

Lindlein P., Mostert W.: Financing Instruments for Renewable Energy, Part of World Bank's "Road Map for Scaling up Access to Modern Energy Services and Clean Energy", World Bank, Washington DC, 2005, Chapter 4.4.5 on smart subsidies" (page 75)

Reiche K., Teplitz: Energy Subsidies: Why, When and How? GTZ 2008

Perman, R., & Perman, R. (2003). Natural resource and environmental economics. Harlow, England: Pearson Addison Wesley.

Smart subsidies: Getting the conditions right - The experience of expanding rural telecoms in Nepal <http://www.lirneasia.net/wp-content/uploads/2006/02/de%20Silva%20Tuladhar%202006%20Nepal%20final.pdf>

Smart Subsidy for sustainable microfinance http://www.ruralfinance.org/servlet/BinaryDownloaderServlet/29361_Document.pdf?filename=1133368408225_Smart_subsidy_for_sustainable_microfinance.pdf&refID=29361

ICT Regulation Toolkit, section 7: <http://www.ictregulationtoolkit.org/en/Section.3296.html>

UNEP (2008). Reforming Energy Subsidies - Opportunities to Contribute to the Climate Change Agenda, United Nations Environment Programme, Division of Technology, Industry and Economics. www.unep.org/pdf/PressReleases/Reforming_Energy_Subsidies.pdf

Deutsche Gesellschaft für
Technische Zusammenarbeit (GTZ) GmbH
HERA. Poverty-oriented basic energy services
Dag-Hammarskjöld-Weg 1-5
65760 Eschborn / Germany
T +49 6196 79 1361
F +49 6196 79 80 1361
E hera@gtz.de
I www.gtz.de
www.gtz.de/hera

