



Challenges in Emerging Markets – Berlin 10th October

Tony P. Adam, LL.M.

Nordex is an established global manufacturer of wind energy systems



Nordex at a Glance

- Global manufacturer of wind energy systems with a focus on turbines in MW Class
 - ▶ Founded in 1985 in Denmark
 - ▶ IPO in 2001
- Exceptional revenue growth track record and strong future growth potential
 - ▶ 2004 revenues: €214m
 - ▶ 2006 revenues: €514m
 - ▶ 2011e revenues: €4.0bn
- Main production sites in Germany (Rostock) and China (Dongying, Yinchuan)
- Headquartered in Germany (Norderstedt)
- 1,342 employees

Installed Base by Geography

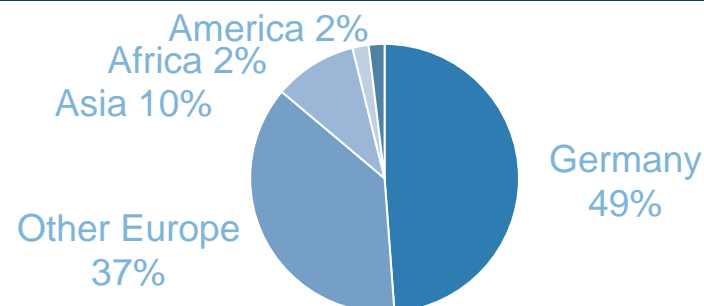

Installed Base by Segment

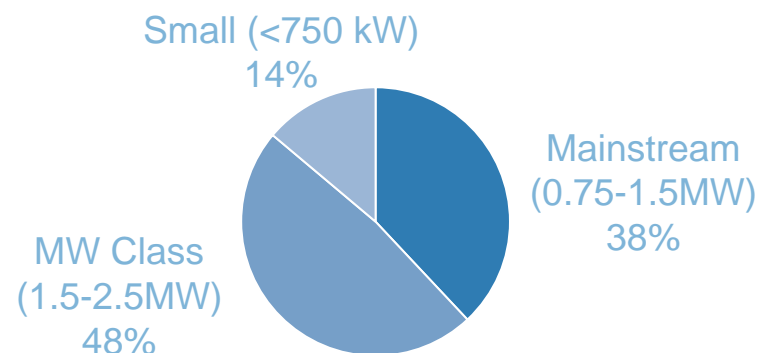

Total (as of Dec-2006): 3,150 MW

Nordex is active throughout the value chain

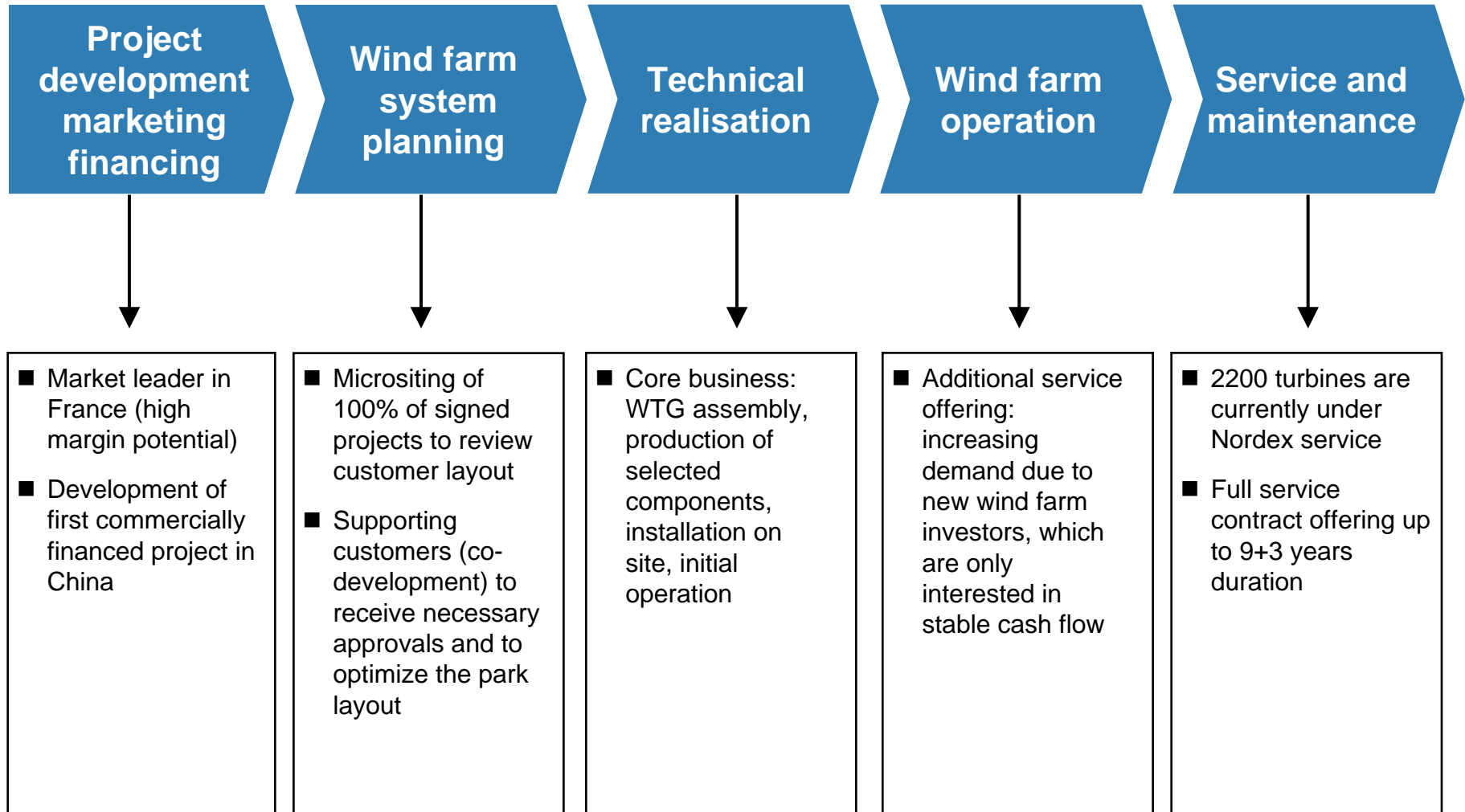

Well established presence in and increasing exposure to growth regions



Established Global Production, Sales and Distribution Network

Headquarters (●):

Norderstedt

Production Sites (●):

Rostock

Yinchuan

Dongying

Branches (●):

Nordex France:

Paris

Nordex UK:

Manchester

Nordex Italia:

Milan

Nordex Scandinavia:

Kolding, Uppsala

Nordex China:

Beijing

Nordex Iberica:

Barcelona

Nordex Polen:

Warsaw

■ Countries / regions with main service activities.

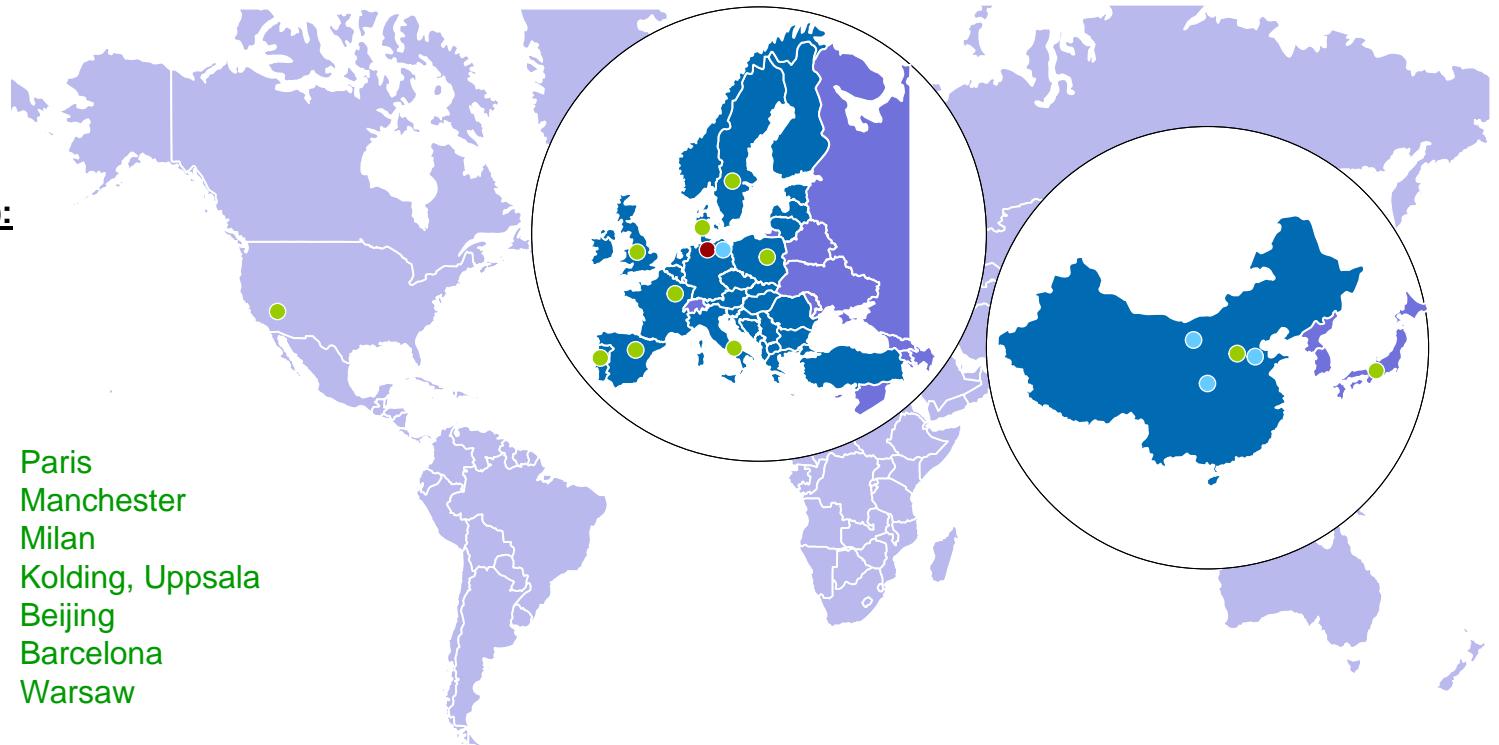

- Increasing presence in China and planned re-entry into the U.S.A. will make Nordex a truly global player
- Largely diversified client base already today; only 14% of 2006 new order intake coming from Germany

Challenges in Emerging Markets



Challenges

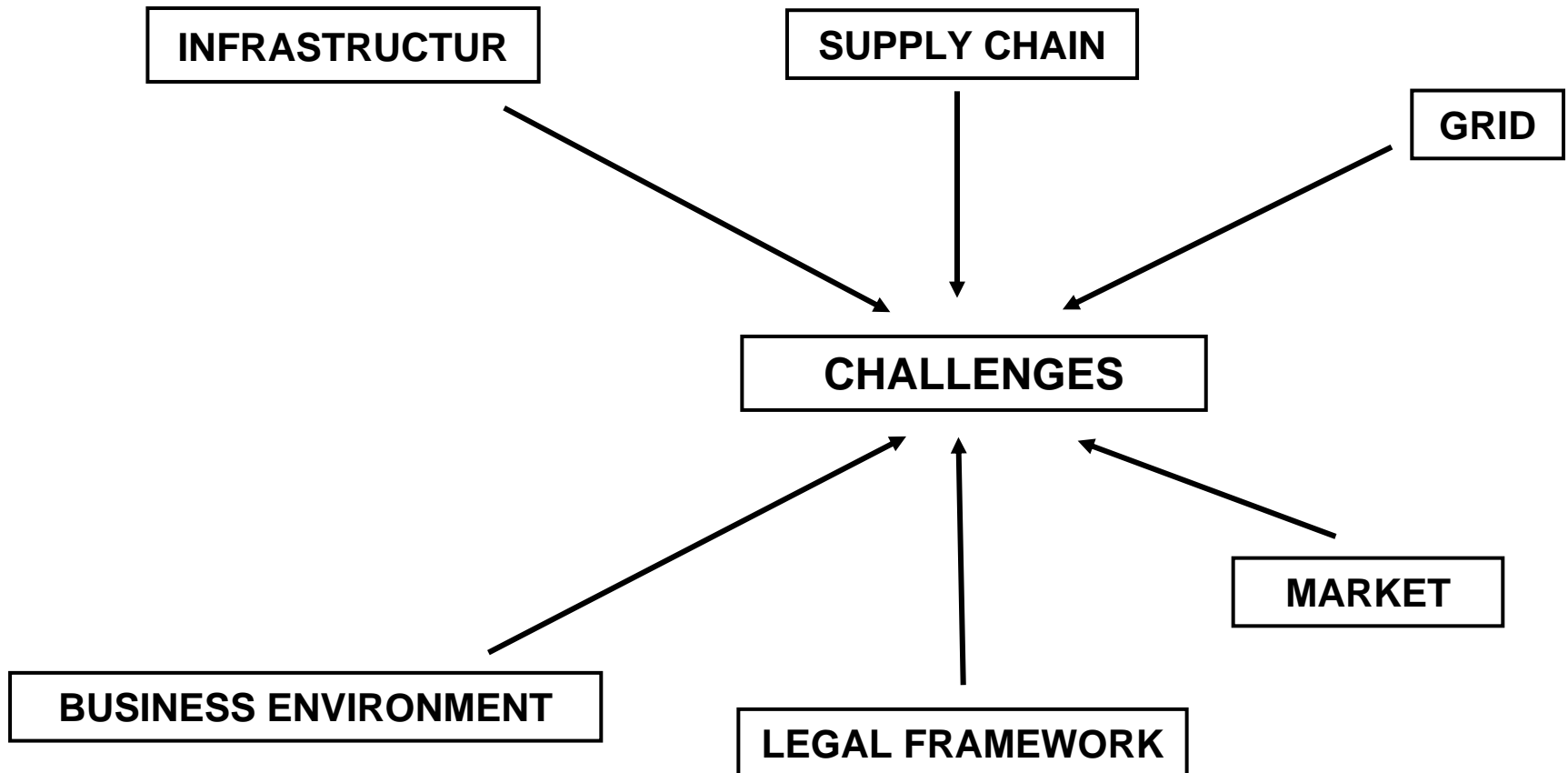

Legal Framework



- Laws supporting renewable energy
 - ▶ Best if clear so that investors know what to expect
 - ▶ Should provide for procedures for planning and permission
- Commercial Law
 - ▶ Corporate structures / Business models
 - ▶ Contracting
- Taxes & Export/Import Regulation
 - ▶ Restrictive Import Duties
 - ▶ Protective Taxes

Business Environment



- Key Players in the Market
 - ▶ What is their role
 - ▶ What are their targets
- Size / Sustainability of the market
 - ▶ Investments need to be assured for the future
 - ▶ Investments are often followed by investments in to the future
 - ▶ Principles that drive the market
- Business rules
 - ▶ OECD standards
- Financing

Challenge – Current Market Situation



- Demand for wind turbines is exceeding supply
 - ▶ Shortage of turbines
 - ▶ Price increase of raw materials
- Supply constraints still remain
 - ▶ Whole value chain under 100% utilization (incl. 2nd tier suppliers)
 - ▶ Huge investment plans implemented on supply side
 - ▶ Supply situation is expected to ease in 2008/09
- Increased attractiveness of renewable energy
 - ▶ Oil is trading above 75 USD/bbl
 - ▶ Rise of renewable energy targets

Globally growing markets



BTM growth projection until 2011 by region

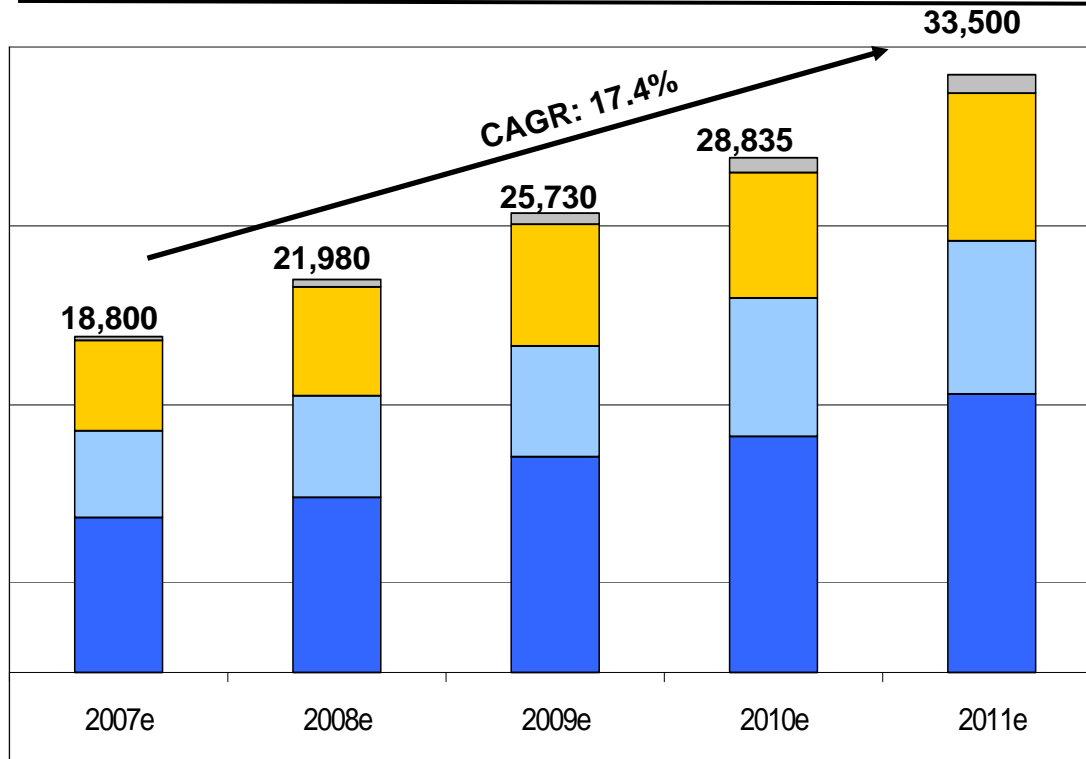

Source: BTM 2007

■ Europe ■ Americas ■ Asia/Pacific ■ RoW

New installations 2007-11

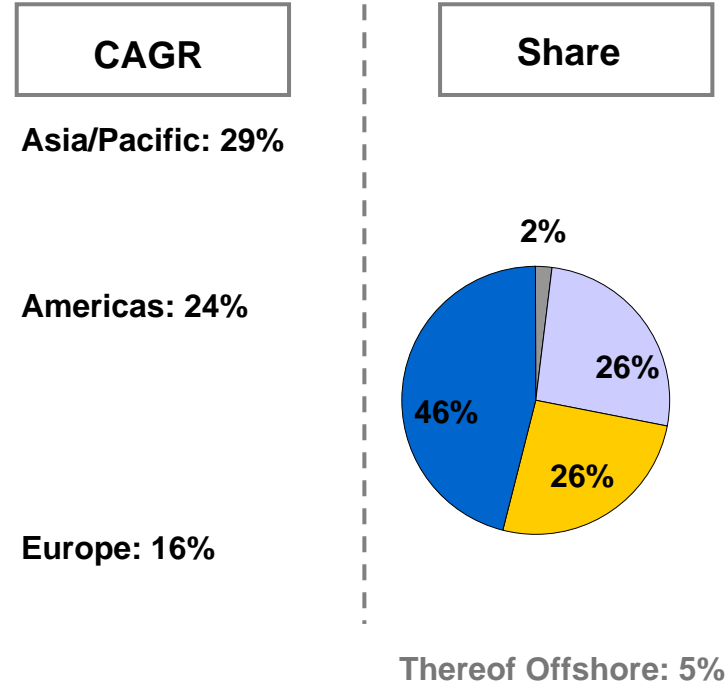

Challenge - Supply Chain



- Supply Chain
 - ▶ Information on local suppliers
 - ▶ Potential Suppliers
 - ▶ Quality
 - ▶ Quantity
 - ▶ Kind of Components



- Grid
 - ▶ Information on Grid
 - ▶ Grid Codes
 - ▶ Availability
 - ▶ Capability
 - ▶ Resources for grid extension

Infrastructure - Dimensions of a wind turbine

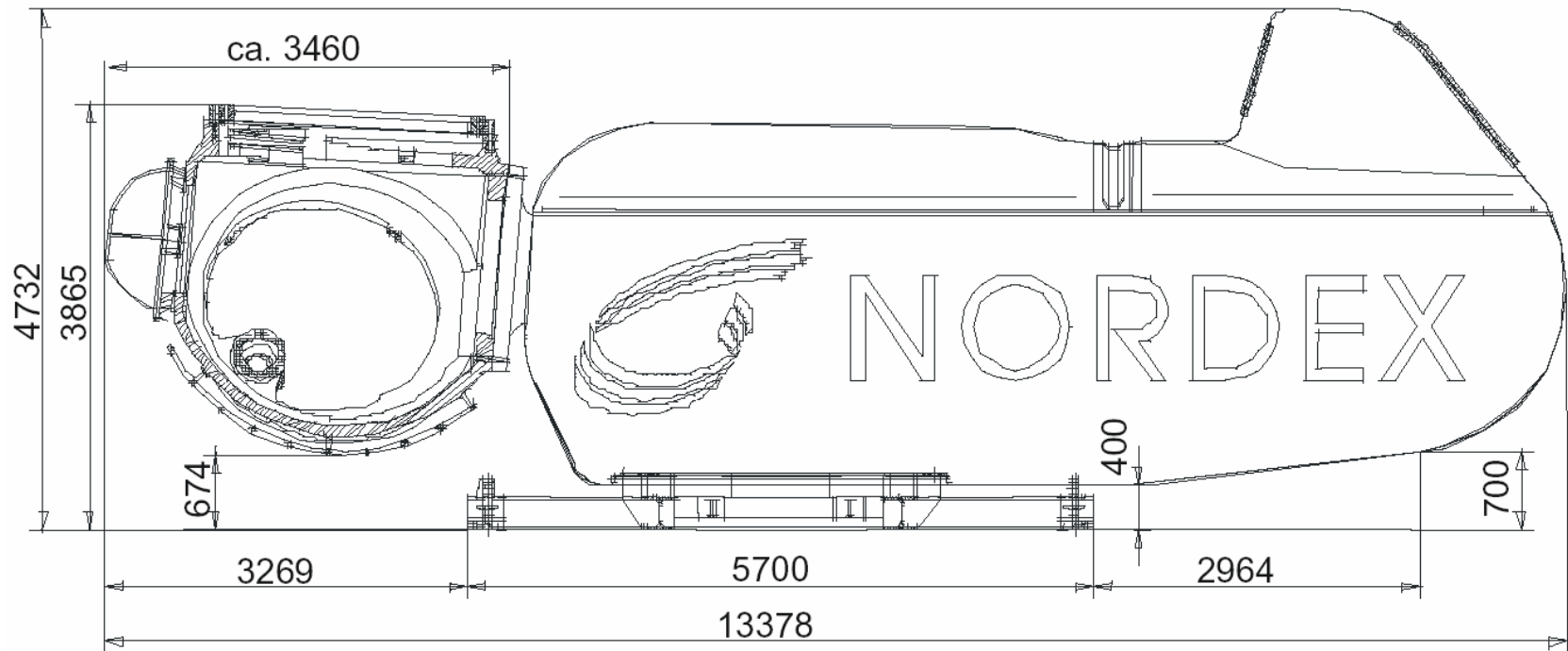

Infrastructure - Transport



- Infrastructure
 - ▶ Capacity / Capability
 - ▶ Resources for Construction
 - ▶ Availability



Nordex - Localisation Example China



Nacelle Manufactory in Yingchuan – Production online since November 2006

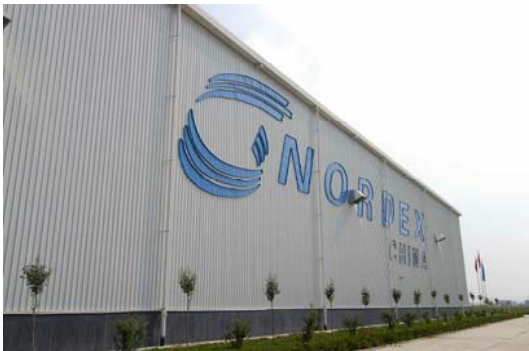

Rotorblade Factory in Dongying production online since January 2007

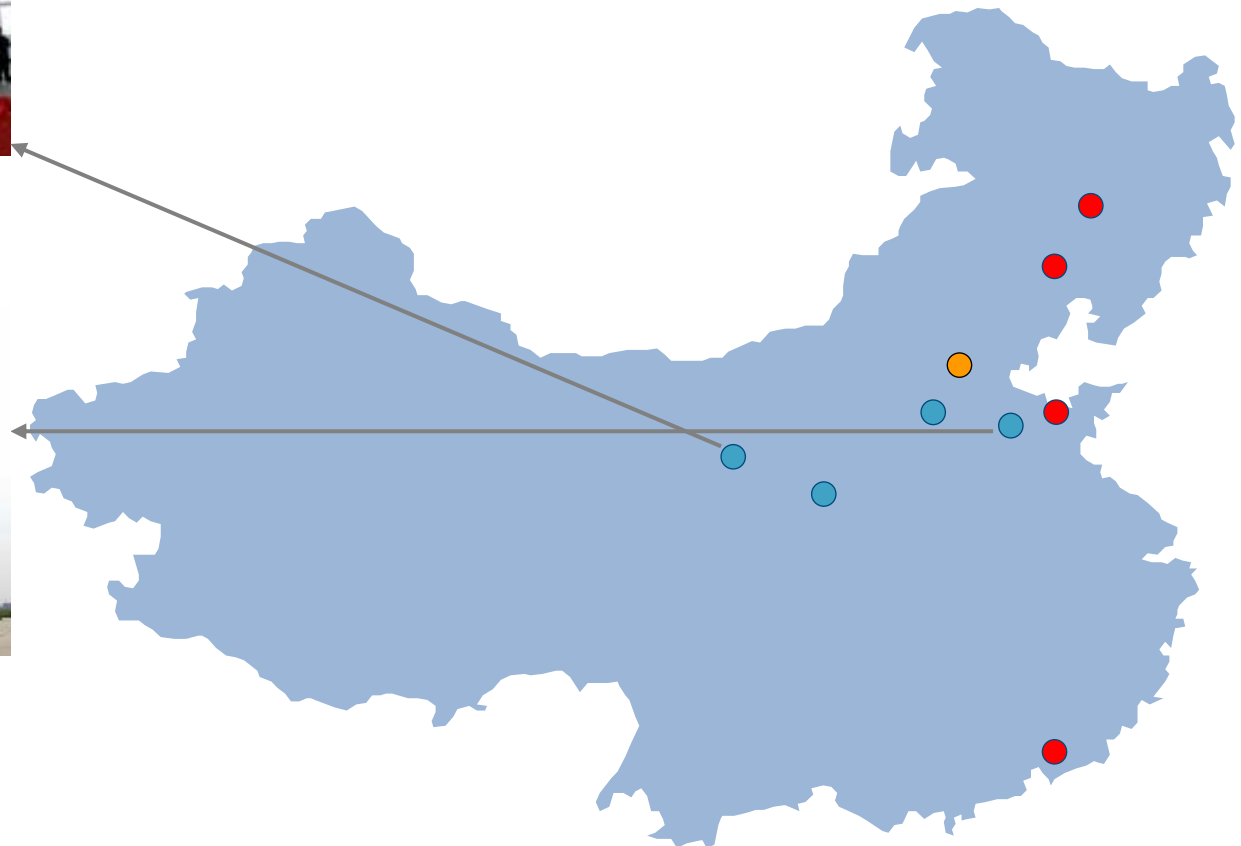

- Service-Station
- Produktion
- Hauptsitz (Peking)

Nordex Projects in China



Nordex – Jeparachi, Columbia



Nordex – Zafarana Egypt

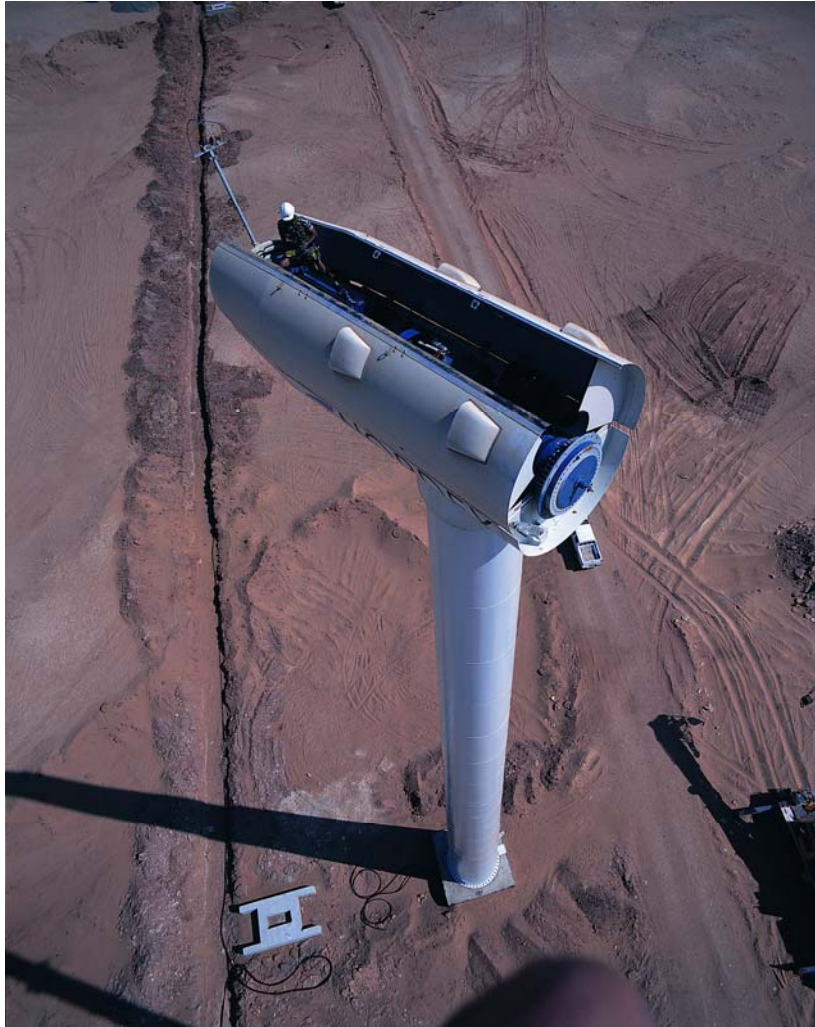

Thanks a lot for your attention



www.nordex-online.com